

PARTS LIST						
ITEM	QTY	PART NO.	PART DESCRIPTION	LENGTH	UNIT WT.	NET WT.
1	2	RCCLIP	ROOFTOP COVER CLIP ANGLE		0.36	0.71
2	2	RCCLIP2	ROOFTOP COVER CLIP LONG		0.62	1.25
3	2	G38112	3/8" x 1-1/2" HDG HEX BOLT GR5		0.07	0.14
4	6	G38FW	3/8" HDG USS FLATWASHER		0.01	0.07
5	4	G38LW	3/8" HDG LOCKWASHER		0.01	0.03
6	4	G38NUT	3/8" HDG HEAVY 2H HEX NUT		0.03	0.14
7	2	X-JB8	J-BOLT, 3/8" X 8" X 6" THREADED		0.33	0.66
8	1	GC4095	1/4" Gr. 40 GALV. CHAIN, 9-1/2'		6.57	6.57
					TOTAL WT. #	9.56

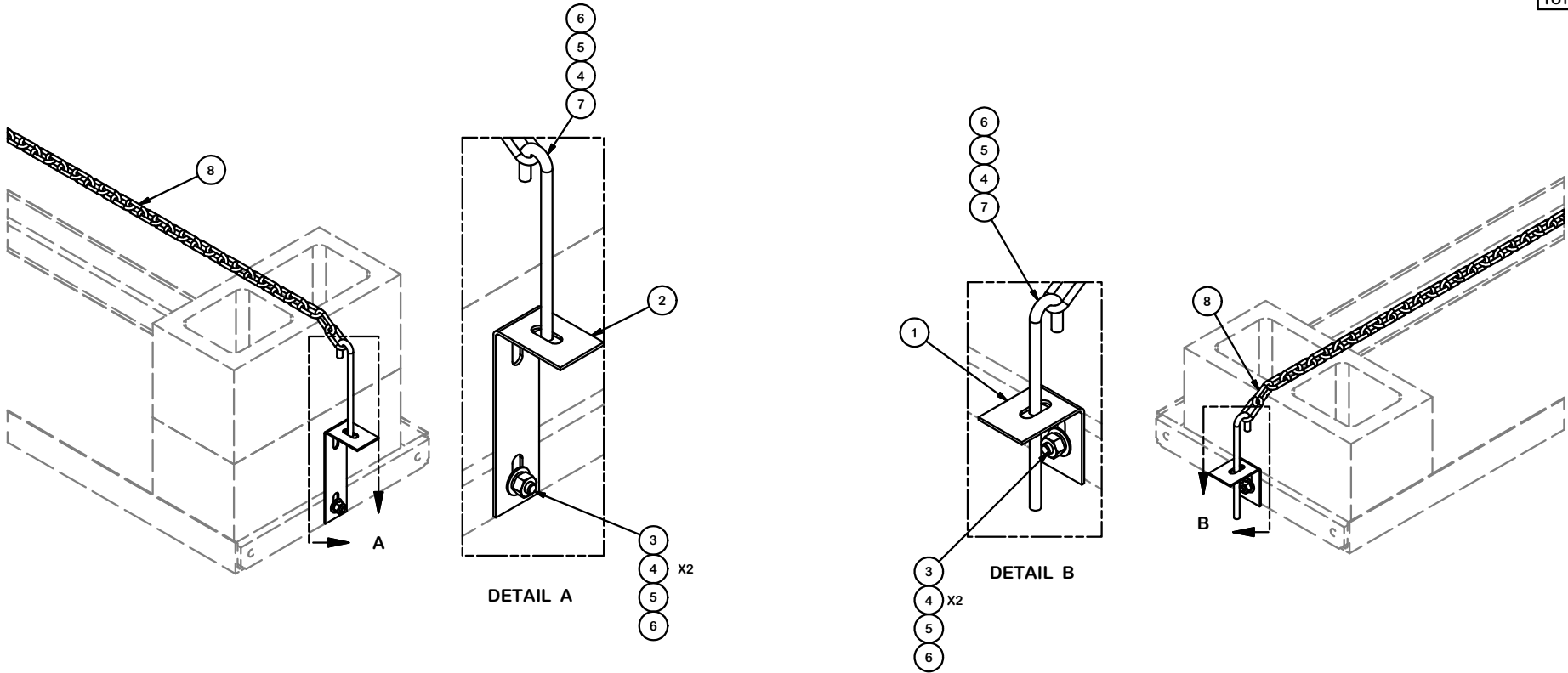

**TOLERANCE NOTES**

TOLERANCES ON DIMENSIONS, UNLESS OTHERWISE NOTED ARE:  
 SAWED, SHEARED AND GAS CUT EDGES ( $\pm 0.030"$ )  
 DRILLED AND GAS CUT HOLES ( $\pm 0.030"$ ) - NO CONING OF HOLES  
 LASER CUT EDGES AND HOLES ( $\pm 0.010"$ ) - NO CONING OF HOLES  
 BENDS CUT EDGES ARE  $\pm 1/2$  DEGREE  
 ALL OTHER MACHINING ( $\pm 0.030"$ )  
 ALL OTHER ASSEMBLY ( $\pm 0.060"$ )

PROPRIETARY NOTE:  
 THE DATA AND TECHNIQUES CONTAINED IN THIS DRAWING ARE PROPRIETARY INFORMATION OF VALMONT INDUSTRIES AND CONSIDERED A TRADE SECRET. ANY USE OR DISCLOSURE WITHOUT THE CONSENT OF VALMONT INDUSTRIES IS STRICTLY PROHIBITED.

DESCRIPTION  
**BALLAST TIE-DOWN KIT  
 FOR 10' BALLAST TRAYS**



Engineering  
 Support Team:  
 1-888-753-7446

Locations:  
 New York, NY  
 Atlanta, GA  
 Los Angeles, CA  
 Plymouth, IN  
 Salem, OR  
 Dallas, TX

CPD NO.	DRAWN BY CEK 3/24/2015	ENG. APPROVAL
CLASS 81	SUB 02	DRAWING USAGE CUSTOMER
	CHECKED BY BMC 3/24/2015	

PART NO.	<b>BHD10-K</b>	PAGE 1 OF 1
DWG. NO.	<b>BHD10-K</b>	