

PARTS LIST						
ITEM	QTY	PART NO.	PART DESCRIPTION	LENGTH	UNIT WT.	NET WT.
1	2	SHCM-W	CHAIN MOUNT WELDMENT		14.59	29.18
2	2	GC4095	1/4" x GR40 GALV. CHAIN 9.5'		4.07	8.14
3	4	SHCM-T	CHAIN MOUNT TIGHTENER BRACKET	3 in	1.75	7.01
4	4	G1202	1/2" x 2" HDG HEX BOLT GR5	2 in	0.18	0.70
5	12	G12FW	1/2" HDG USS FLATWASHER		0.03	0.41
6	12	G12LW	1/2" HDG LOCKWASHER		0.01	0.17
7	2	X-UB1212	1/2" X 2-1/2" X 4-1/2" X 2" U-BOLT (HDG.)		0.63	1.25
7	2	X-UB1458	1/2" X 4-5/8" X 7" X 3" U-BOLT (HDG)		0.97	1.94
8	12	G12NUT	1/2" HDG HEAVY 2H HEX NUT		0.07	0.86
9	4	JB4	1/2" JAW BOLT (GALV)		0.45	1.78
10	4	G38212	3/8" x 2-1/2" HDG HEX BOLT GR5		0.10	0.41
11	4	G38FW	3/8" HDG USS FLATWASHER		0.01	0.05
12	4	G38LW	3/8" HDG LOCKWASHER		0.01	0.03
13	4	G38NUT	3/8" HDG HEAVY 2H HEX NUT		0.03	0.14
					TOTAL WT. #	52.07

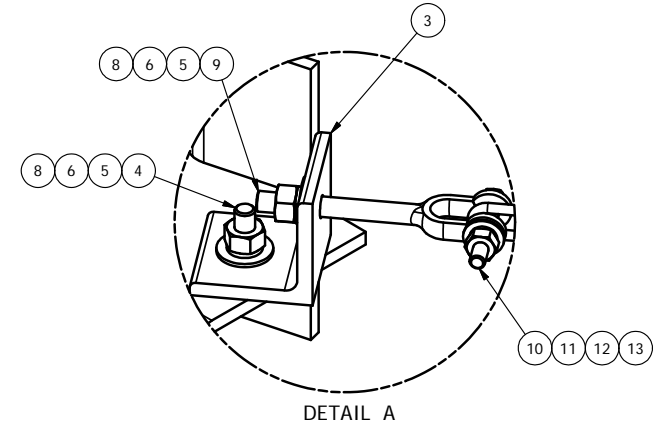

TOLERANCE NOTE
TOLERANCES ON DIMENSIONS, UNLESS OTHERWISE NOTED ARE:
SAWED, SHEARED AND GAS CUT EDGES ($\pm 0.030"$)
DRILLED AND GAS CUT HOLES ($\pm 0.030"$) - NO CONING OF HOLES
LASER CUT EDGES AND HOLES ($\pm 0.010"$) - NO CONING OF HOLES
BENDS ARE $\pm 1/2$ DEGREE - ALL OTHER MACHINING ($\pm 0.030"$)
ALL OTHER ASSEMBLY ($\pm 0.060"$)

PROPRIETARY NOTE
 THE DATA AND TECHNIQUES CONTAINED IN THIS DRAWING ARE PROPRIETARY INFORMATION OF VALMONT INDUSTRIES AND CONSIDERED A TRADE SECRET. ANY USE OR DISCLOSURE WITHOUT THE CONSENT OF VALMONT INDUSTRIES IS STRICTLY PROHIBITED.

DESCRIPTION		SINGLE SECTOR CHAIN MOUNT	
DRAWN BY	CPD NO.	DRAWING USAGE	PART NO.
CEK	1/12/2012	CUSTOMER	CHM1
ENG. APPROVAL	CHECKED BY	DWG. NO.	CHM1
	BMC	1/16/2012	

SITE PRO 1
 Engineering Support Team:
 1-888-753-7446

Locations:
 New York, NY
 Atlanta, GA
 Los Angeles, CA
 Plymouth, IN
 Salem, OR
 Dallas, TX

A valmont COMPANY