

PARTS LIST						
ITEM	QTY	PART NO.	PART DESCRIPTION	LENGTH	UNIT WT.	NET WT.
1	2	X-154463	UNIVERSAL PIPE MOUNTING PLATE (INNER)		10.52	21.03
2	2	X-155561	UNIVERSAL PIPE MOUNTING PLATE (OUTER)		13.16	26.31
3	2	X-159999	BACKING PLATE		5.73	11.46
4	1	X-151364	STRUT ARM FOR LIGHTWEIGHT T-FRAME		72.39	72.39
5	1	X-151370	LIGHTWEIGHT T-FRAME MOUNTING ARM, 78" LONG		65.55	65.55
6	1	X-151367	LIGHTWEIGHT T-FRAME MOUNTING ARM, 66" LONG		53.50	53.50
7	1	P472	4-1/2" X 72" SCH. 40 GALVANIZED PIPE		64.89	64.89
8	2	P1126	1 1/4" X 126" SCH 40 PIPE (STIFF ARM)		25.12	50.23
9	3	A	2-3/8" Sch 40 Galvanized Pipe	B	See Table	See Table
10	8	X-123614	FLAT DISK CLAMP PLATE 3" CENTERS (GALVANIZED)		1.52	12.12
11	16	X-116165	3" V-CLAMP		0.74	11.88
12	2	X-127594	FLAT DISK CLAMP PLATE 4" CENTERS (GALVANIZED)		2.48	4.97
13	4	X-100064	CLAMP (S) (4" V-CLAMP) GALVANIZED		0.91	3.65
14	1	X-115765	5" V-CLAMP		1.02	1.02
15	4	G5802	5/8" x 2" HDG HEX BOLT GR5		0.27	1.09
16	4	G58FW	5/8" HDG USS FLATWASHER		0.07	0.28
17	4	G58LW	5/8" HDG LOCKWASHER		0.03	0.10
18	4	G58NUT	5/8" HDG HEAVY 2H HEX NUT		0.13	0.52
19	28	G1204	1/2" x 4" HDG HEX BOLT GR5 FULL THREAD		0.27	7.56
20	12	G12065	1/2" x 6-1/2" HDG HEX BOLT GR5 FULL THREAD		0.41	4.91
21	16	G1203	1/2" x 3" HDG HEX BOLT GR5 FULL THREAD	3	0.22	3.47
22	4	G12212	1/2" x 2-1/2" HDG HEX BOLT GR5		0.20	0.81
23	9	X-UB1458	1/2" X 4-5/8" X 7" X 3" GALV U-BOLT		0.97	8.74
24	66	G12FW	1/2" HDG USS FLATWASHER		0.03	2.25
25	70	G12LW	1/2" HDG LOCKWASHER		0.01	0.97
26	70	G12NUT	1/2" HDG HEAVY 2H HEX NUT		0.07	5.01
					TOTAL WT. #	See Table

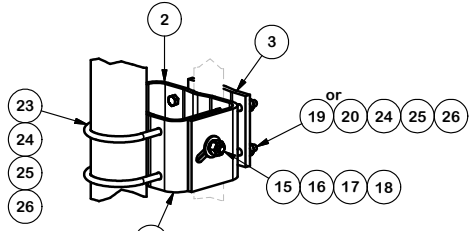

DETAIL A

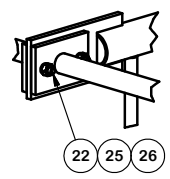

DETAIL C

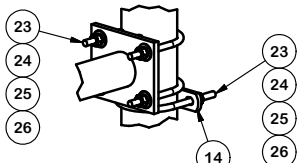

DETAIL B

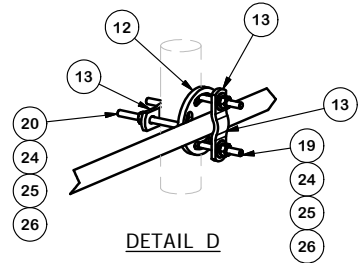

DETAIL D

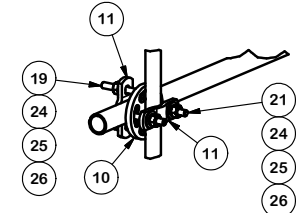

DETAIL E

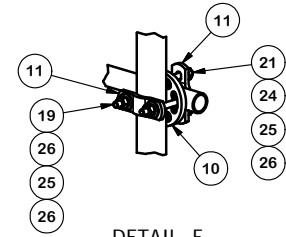

DETAIL F

TABLE					
Part #	A	B	"A" UNIT WT.	"A" NET WT.	TOTAL WT. #
LTF12-372	P272	72"	23.07	69.21	500.61
LTF12-384	P284	84"	26.91	80.73	512.14
LTF12-396	P296	96"	300.76	92.28	523.68

TOLERANCE NOTES
 TOLERANCES ON DIMENSIONS, UNLESS OTHERWISE NOTED ARE:
 SAWED, SHEARED AND GAS CUT EDGES ($\pm 0.030"$)
 DRILLED AND GAS CUT HOLES ($\pm 0.030"$) - NO CONING OF HOLES
 LASER CUT EDGES AND HOLES ($\pm 0.010"$) - NO CONING OF HOLES
 BENDS ARE $\pm 1/2$ DEGREE
 ALL OTHER MACHINING ($\pm 0.030"$)
 ALL OTHER ASSEMBLY ($\pm 0.060"$)

PROPRIETARY NOTE:
 THE DATA AND TECHNIQUES CONTAINED IN THIS DRAWING ARE PROPRIETARY INFORMATION OF VALMONT INDUSTRIES AND CONSIDERED A TRADE SECRET. ANY USE OR DISCLOSURE WITHOUT THE CONSENT OF VALMONT INDUSTRIES IS STRICTLY PROHIBITED.

DESCRIPTION
 12'
 LIGHTWEIGHT T-FRAME
 W/ (2) STIFF ARMS

CPD NO. 4838
 CLASS 81 SUB 01

DRAWN BY
 RH18 10/15/2010

DRAWING USAGE
 CUSTOMER

ENG. APPROVAL
 CHECKED BY
 BMC 10/22/2010

SITE PRO 1
 Engineering Support Team:
 1-888-753-7446

Locations:
 New York, NY
 Atlanta, GA
 Los Angeles, CA
 Plymouth, IN
 Salem, OR
 Dallas, TX

PART NO. SEE TABLE
 DWG. NO. LTF12-3XX

PAGE 1 OF 2

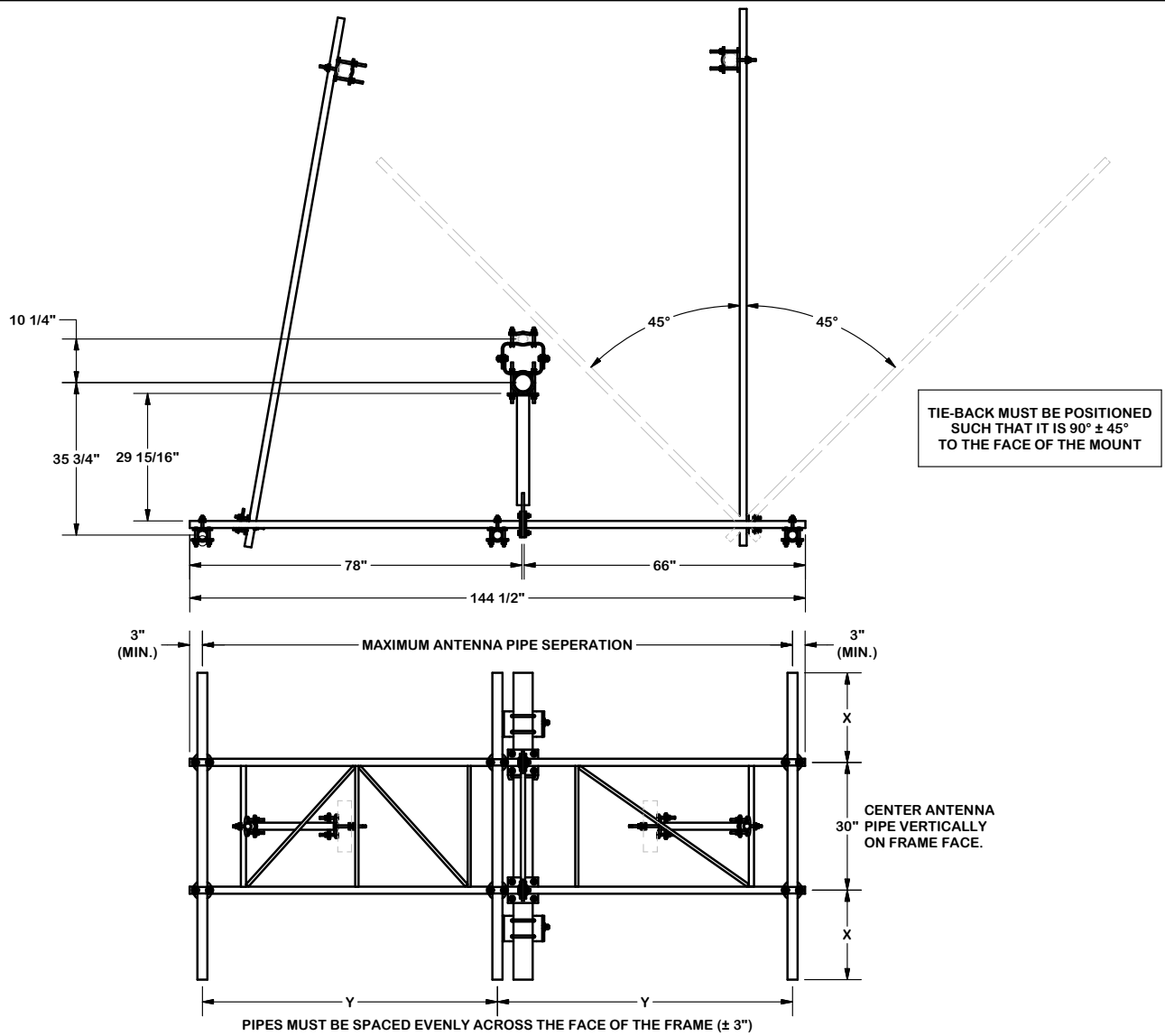

TIE-BACK MUST BE POSITIONED SUCH THAT IT IS 90° ± 45° TO THE FACE OF THE MOUNT

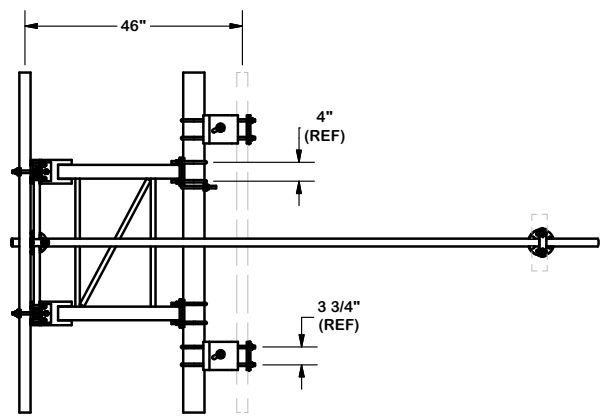

TOLERANCE NOTES

TOLERANCES ON DIMENSIONS, UNLESS OTHERWISE NOTED ARE:
 SAWED, SHEARED AND GAS CUT EDGES ($\pm 0.030"$)
 DRILLED AND GAS CUT HOLES ($\pm 0.030"$) - NO CONING OF HOLES
 LASER CUT EDGES AND HOLES ($\pm 0.010"$) - NO CONING OF HOLES
 BENDS ARE $\pm 1/2$ DEGREE
 ALL OTHER MACHINING ($\pm 0.030"$)
 ALL OTHER ASSEMBLY ($\pm 0.060"$)

PROPRIETARY NOTE:
 THE DATA AND TECHNIQUES CONTAINED IN THIS DRAWING ARE PROPRIETARY INFORMATION OF VALMONT INDUSTRIES AND CONSIDERED A TRADE SECRET. ANY USE OR DISCLOSURE WITHOUT THE CONSENT OF VALMONT INDUSTRIES IS STRICTLY PROHIBITED.

DESCRIPTION
 12'
 LIGHTWEIGHT T-FRAME
 W/ (2) STIFF ARMS

CPD NO. 4838	DRAWN BY RH18 10/15/2010	ENG. APPROVAL
CLASS 81	SUB 01	DRAWING USAGE CUSTOMER
		CHECKED BY BMC 10/22/2010



Locations:
 New York, NY
 Atlanta, GA
 Los Angeles, CA
 Plymouth, IN
 Salem, OR
 Dallas, TX

Engineering Support Team:
 1-888-753-7446

PART NO.	SEE TABLE	PAGE 2 OF 2
DWG. NO.	LTF12-3XX	