

PARTS LIST						
ITEM	QTY	PART NO.	PART DESCRIPTION	LENGTH	UNIT WT.	NET WT.
1	2	X-123614	FLAT DISK CLAMP PLATE 3" CENTERS		1.52	3.03
2	4	X-116165	3" V-CLAMP		1.03	4.12
3	8	G1204	1/2" x 4" HDG HEX BOLT GR5 FULL THREAD	4 in	0.27	2.16
4	8	G12FW	1/2" HDG USS FLATWASHER		0.03	0.27
5	8	G12LW	1/2" HDG LOCKWASHER		0.01	0.11
6	8	G12NUT	1/2" HDG HEAVY 2H HEX NUT		0.07	0.57
					TOTAL WT. #	11.41

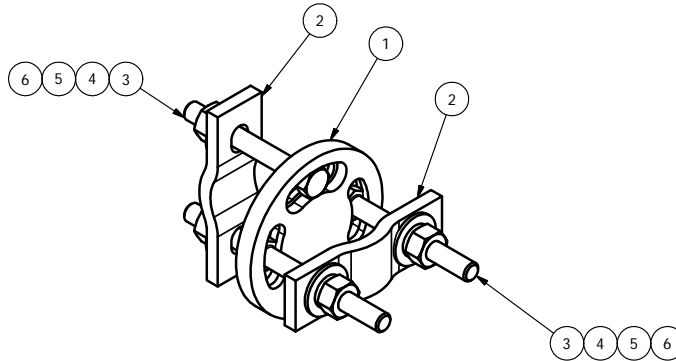
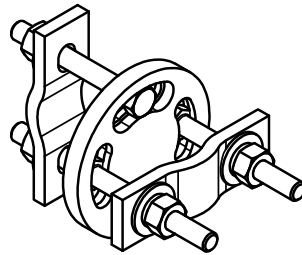

PROPRIETARY NOTE:
THE DATA AND TECHNIQUES CONTAINED IN THIS DRAWING ARE PROPRIETARY INFORMATION OF VALMONT INDUSTRIES AND CONSIDERED A TRADE SECRET. ANY USE OR DISCLOSURE WITHOUT THE CONSENT OF VALMONT INDUSTRIES IS STRICTLY PROHIBITED.

TOLERANCE NOTE:
TOLERANCES ON DIMENSIONS UNLESS OTHERWISE NOTED ARE (PLUS OR MINUS) MACHINING 0.030" AND STRUCTURAL 0.060". BENDS ARE (+ OR -) 1/2 DEGREE.

DESCRIPTION
ADJUSTABLE CLAMP PLATE
TIE-BACK ASSEMBLY

valmont 
1-877-467-4763 Plymouth, IN
1-888-880-9191 Salem, OR
STRUCTURES

DRAWN BY CEK 5/11/2011	CPD NO.	DRAWING USAGE CUSTOMER
ENG. APPROVAL	CHECKED BY BMC	5/11/2011

PART NO. PUCK3	PAGE 1 OF 1
DWG. NO. PUCK3	