

PARTS LIST						
ITEM	QTY	PART NO.	PART DESCRIPTION	LENGTH	UNIT WT.	NET WT.
1	3	X-LWRM	RING MOUNT WELDMENT		68.81	206.42
2	9	G58R-24	5/8" x 24" THREADED ROD (HDG.)		0.40	3.59
2	9	G58R-48	5/8" x 48" THREADED ROD (HDG.)		0.40	3.59
3	3	X-SV196	LOW PROFILE PLATFORM CORNER		212.10	636.31
4	12	A58234	5/8" x 2-3/4" HDG A325 HEX BOLT	2.75	0.36	4.27
5	12	A58FW	5/8" HDG A325 FLATWASHER		0.03	0.41
6	30	G58LW	5/8" HDG LOCKWASHER		0.03	0.78
7	30	A58NUT	5/8" HDG A325 HEX NUT		0.13	3.90
8	3	P3150	3-1/2" X 150" SCH 40 GALVANIZED PIPE	150.000 in	94.80	284.40
9	30	X-UB1306	1/2" X 3-5/8" X 6" X 3" U-BOLT (HDG.)		0.26	7.71
10	96	G12FW	1/2" HDG USS FLATWASHER		0.03	3.27
11	96	G12LW	1/2" HDG LOCKWASHER		0.01	1.33
12	96	G12NUT	1/2" HDG HEAVY 2H HEX NUT		0.07	6.88
13	9	X-SP219	SMALL SUPPORT CROSS PLATE	8.250 in	8.61	77.50
14	18	X-UB1212	1/2" X 2-1/2" X 4-1/2" X 2" U-BOLT (HDG.)		0.26	4.63
15	9	B	ANTENNA MOUNTING PIPE	C	D	E

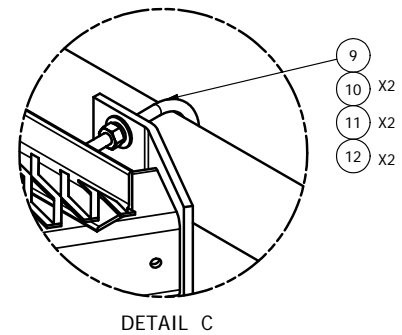
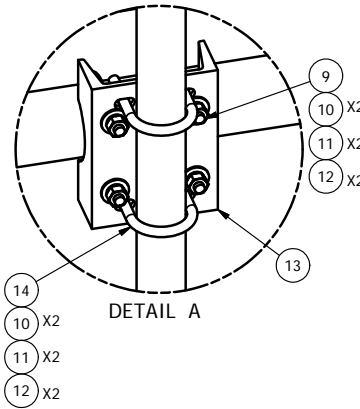

2-3/8" O.D. VERTICAL MOUNTING PIPES					
ASSEMBLY NO. "A"	PART NO. "B"	LENGTH, "C"	UNIT WEIGHT, "D"	NET WEIGHT, "E"	TOTAL WEIGHT
RMQP-363	P263	63"	20.18	181.62	1494.37
RMQP-372	P272	72"	23.07	207.63	1520.38
RMQP-384	P284	84"	26.91	242.19	1554.94
RMQP-396	P296	96"	30.76	276.84	1589.59
RMQP-3126	P2126	126"	40.75	366.75	1679.50

TOLERANCE NOTE

TOLERANCES ON DIMENSIONS, UNLESS OTHERWISE NOTED ARE: SAWED, SHEARED AND GAS CUT EDGES (± 0.030") DRILLED AND GAS CUT HOLES (± 0.030") - NO CONING OF HOLES LASER CUT EDGES AND HOLES (± 0.010") - NO CONING OF HOLES BENDS ARE ± 1/2 DEGREE - ALL OTHER MACHINING (± 0.030") ALL OTHER ASSEMBLY (± 0.060")

PROPRIETARY NOTE

THE DATA AND TECHNIQUES CONTAINED IN THIS DRAWING ARE PROPRIETARY INFORMATION OF VALMONT INDUSTRIES AND CONSIDERED A TRADE SECRET. ANY USE OR DISCLOSURE WITHOUT THE CONSENT OF VALMONT INDUSTRIES IS STRICTLY PROHIBITED.

DESCRIPTION

LOW PROFILE CO-LOCATION PLATFORM FOR 9 ANTENNAS WITH 12' 6" FACE WIDTH FOR 12" - 38" DIAMETER POLES



Engineering Support Team: 1-888-753-7446

Locations: New York, NY
Atlanta, GA
Los Angeles, CA
Plymouth, IN
Salem, OR
Dallas, TX

DRAWN BY

CEK 1/19/2012

CPD NO.

semb

DRAWING USAGE

CUSTOMER

ENG. APPROVAL

BMC

1/23/2012

PART NO.

SEE ASSEMBLY NO. "A"

DWG. NO.

RMQP-3XX

REV	DESCRIPTION OF REVISIONS	CPD	BY	DATE
A	ADDED 10' 6" ANTENNA MOUNTING PIPES	CEK	7/7/2015	
REVISION HISTORY				

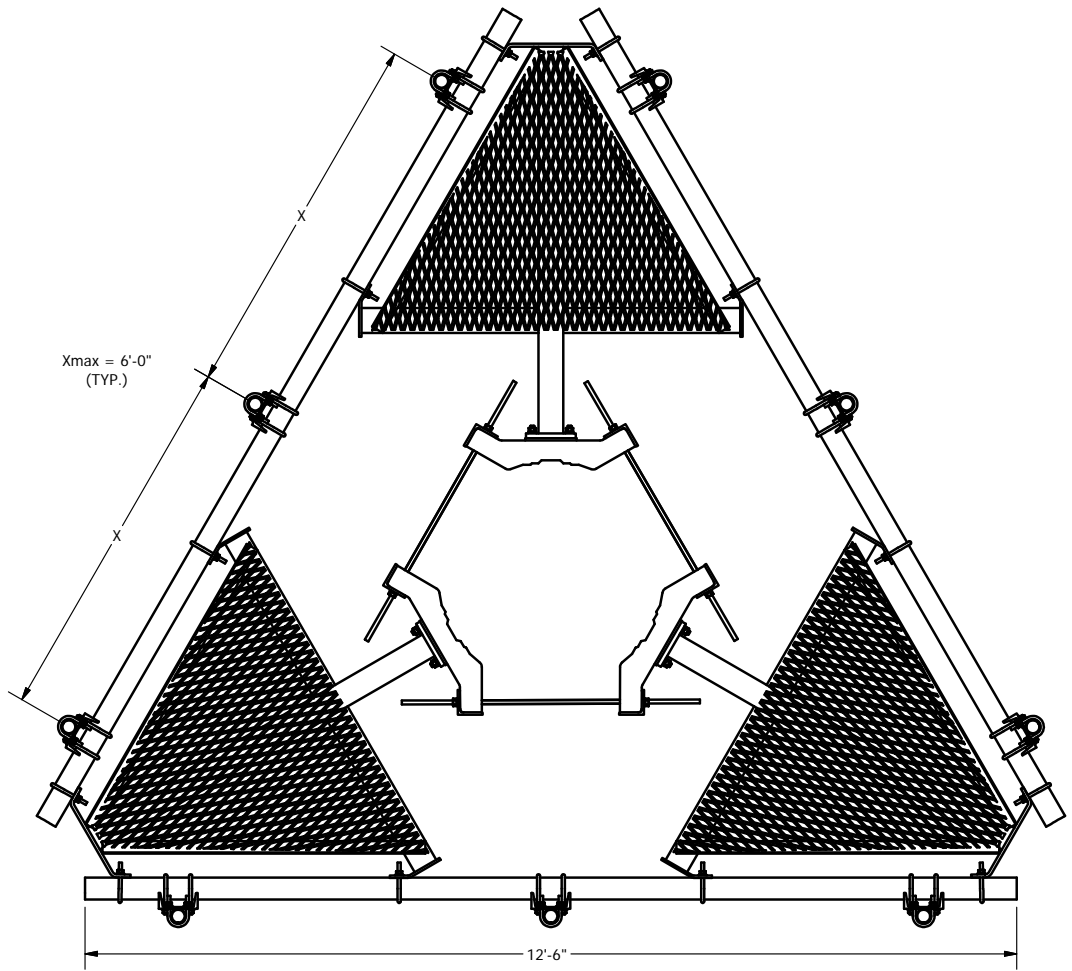

TOLERANCE NOTE

**TOLERANCES ON DIMENSIONS, UNLESS OTHERWISE NOTED ARE:
 SAWED, SHEARED AND GAS CUT EDGES (± 0.030 ")
 DRILLED AND GAS CUT HOLES (± 0.030 ") - NO CONING OF HOLES
 LASER CUT EDGES AND HOLES (± 0.010 ") - NO CONING OF HOLES
 BENDS ARE $\pm 1/2$ DEGREE - ALL OTHER MACHINING (± 0.030 ")
 ALL OTHER ASSEMBLY (± 0.060 ")**

PROPRIETARY NOTE

THE DATA AND TECHNIQUES CONTAINED IN THIS DRAWING ARE PROPRIETARY INFORMATION OF VALMONT INDUSTRIES AND CONSIDERED A TRADE SECRET. ANY USE OR DISCLOSURE WITHOUT THE CONSENT OF VALMONT INDUSTRIES IS STRICTLY PROHIBITED.

DESCRIPTION
**LOW PROFILE CO-LOCATION PLATFORM
 FOR 9 ANTENNAS WITH 12' 6" FACE WIDTH
 FOR 12" - 38" DIAMETER POLES**

	Engineering Support Team: 1-888-753-7446	Locations: New York, NY Atlanta, GA Los Angeles, CA Plymouth, IN Salem, OR Dallas, TX
	A valmont COMPANY	

DRAWN BY CEK	CPD NO. semb	DRAWING USAGE CUSTOMER
ENG. APPROVAL	CHECKED BY BMC	1/23/2012

PART NO. SEE ASSEMBLY NO. "A"	DWG. NO. RMQP-3XX
2 OF 2	

REV	DESCRIPTION OF REVISIONS	CPD	BY	DATE
A	ADDED 10' 6" ANTENNA MOUNTING PIPES		CEK	7/7/2015
REVISION HISTORY				