

PARTS LIST						
ITEM	QTY	PART NO.	PART DESCRIPTION	LENGTH	UNIT WT.	NET WT.
1	3	X-LWRM	RING MOUNT WELDMENT		68.16	204.48
2	9	G58R-24	5/8" x 24" THREADED ROD (HDG.)		2.09	18.82
2	9	G58R-48	5/8" X 48" GALV THREADED ROD		4.39	39.52
3	3	X-SV197-36	SUPPORT ARM WELDMENT - 36"		67.29	201.88
4	12	A58234	5/8" x 2-3/4" HDG A325 HEX BOLT	2.75	0.36	4.27
5	12	A58FW	5/8" HDG A325 FLATWASHER		0.03	0.41
6	42	G58LW	5/8" HDG LOCKWASHER		0.03	1.09
7	24	A58NUT	5/8" HDG A325 HEX NUT		0.13	3.11
8	6	X-UB5458	5/8" X 4-5/8" X 7" X 3' U-BOLT (HDG.)		0.66	3.94
9	18	G58FW	5/8" HDG USS FLATWASHER		0.07	1.27
10	18	G58NUT	5/8" HDG HEAVY 2H HEX NUT		0.13	2.34
11	24	X-UB1306	1/2" X 3-5/8" X 6" X 3" U-BOLT (HDG.)		0.66	15.75
12	66	G12NUT	1/2" HDG HEAVY 2H HEX NUT		0.07	4.72
13	66	G12FW	1/2" HDG USS FLATWASHER		0.03	2.25
14	66	G12LW	1/2" HDG LOCKWASHER		0.01	0.92
15	12	X-UB1300	1/2" X 3" X 5" X 2" U-BOLT (HDG.)		0.66	7.88
16	3	P360	3-1/2" X 60" SCH 40 GALVANIZED PIPE		37.97	113.90
17	6	A	B	C	D	
18	6	X-SP219	SMALL SUPPORT CROSS PLATE	8.250 in	8.61	51.66
19	3	X-SP216	LARGE SUPPORT CROSS PLATE		20.83	62.48

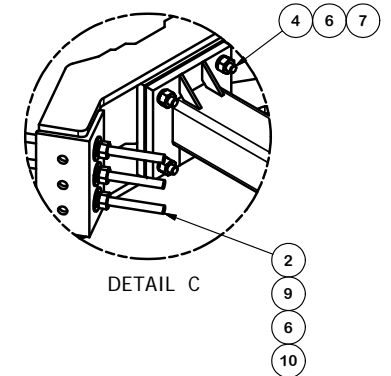
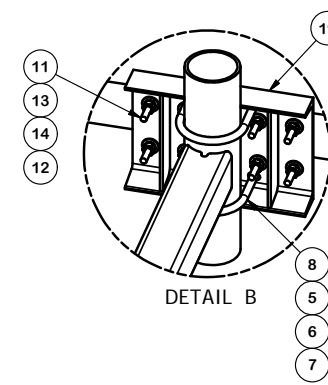

TABLE					
"ASSEMBLY NO."	PART NO. "A"	PART DESCRIPTION "B"	LENGTH "C"	UNIT WT. "D"	TOTAL WT.
RMV5-3072	P3072	2-7/8" O.D. SCH. 40 PIPE	72"	34.84	955.29
RMV5-3084	P3084	2-7/8" O.D. SCH. 40 PIPE	84"	40.65	990.15
RMV5-3096	P3096	2-7/8" O.D. SCH. 40 PIPE	96"	46.45	1,024.95

**TOLERANCE NOTES**  
 TOLERANCES ON DIMENSIONS, UNLESS OTHERWISE NOTED ARE:  
 SAWED, SHEARED AND GAS CUT EDGES ( $\pm 0.030"$ )  
 DRILLED AND GAS CUT HOLES ( $\pm 0.030"$ ) - NO CONING OF HOLES  
 LASER CUT EDGES AND HOLES ( $\pm 0.010"$ ) - NO CONING OF HOLES  
 BENDS ARE  $\pm 1/2$  DEGREE  
 ALL OTHER MACHINING ( $\pm 0.030"$ )  
 ALL OTHER ASSEMBLY ( $\pm 0.060"$ )

PROPRIETARY NOTE:  
 THE DATA AND TECHNIQUES CONTAINED IN THIS DRAWING ARE PROPRIETARY INFORMATION OF VALMONT INDUSTRIES AND CONSIDERED A TRADE SECRET. ANY USE OR DISCLOSURE WITHOUT THE CONSENT OF VALMONT INDUSTRIES IS STRICTLY PROHIBITED.

DESCRIPTION  
**MONOPOLE TRIPLE T-ARM FOR 6 ANTENNAS**

CPD NO. 4543 DRAWN BY CEK 4/15/2011 ENG. APPROVAL  
 CLASS SUB 81 01 DRAWING USAGE CUSTOMER CHECKED BY BMC 4/28/2011

**SITE PRO 1**  
 Engineering Support Team:  
 1-888-753-7446

Locations:  
 New York, NY  
 Atlanta, GA  
 Los Angeles, CA  
 Plymouth, IN  
 Salem, OR  
 Dallas, TX

PART NO. SEE "ASSEMBLY NO."  
 DWG. NO. RMV5-3XXX

1 OF 2

REV	DESCRIPTION OF REVISIONS	CPD	BY	DATE
A	REMOVE FLATWASHERS FROM ARM TO CLAMP RING CONNECTION	CEK		11/4/11
REVISION HISTORY				

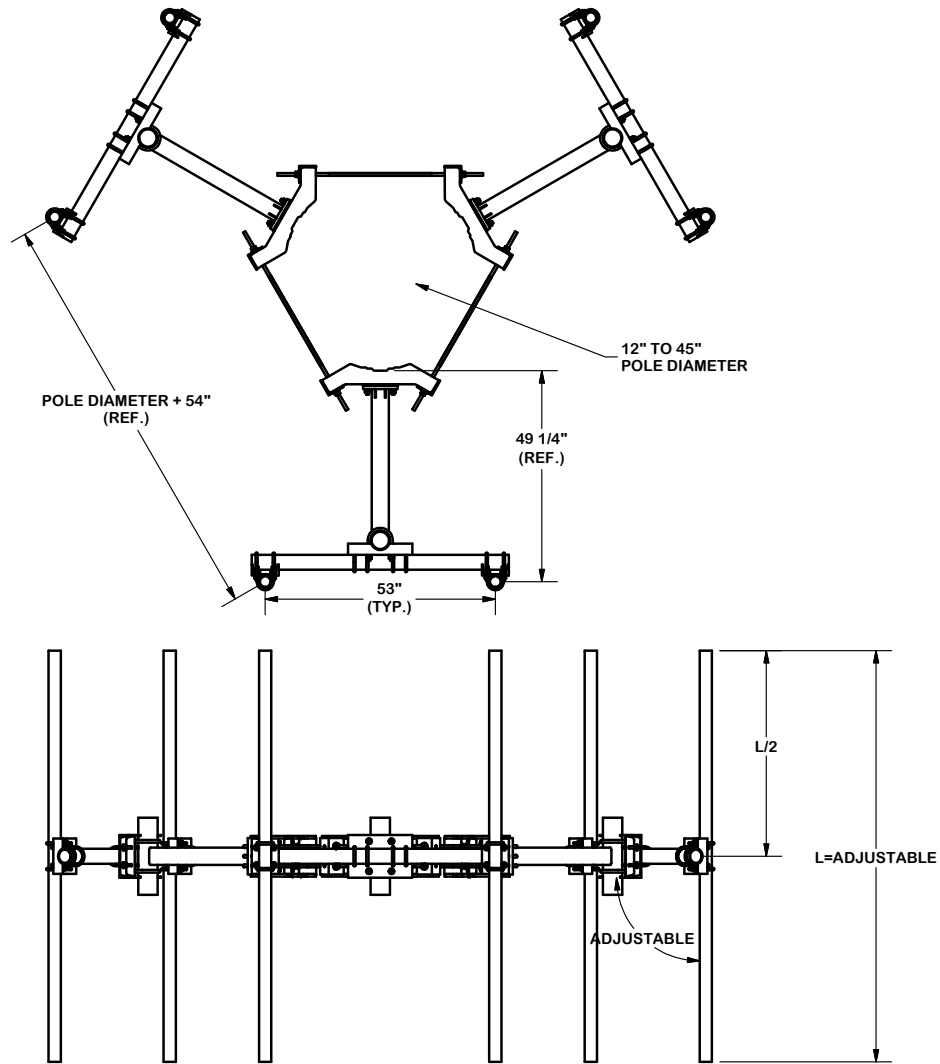

**TOLERANCE NOTES**

TOLERANCES ON DIMENSIONS, UNLESS OTHERWISE NOTED ARE:  
 SAWED, SHEARED AND GAS CUT EDGES ( $\pm 0.030$ " )  
 DRILLED AND GAS CUT HOLES ( $\pm 0.030$ " ) - NO CONING OF HOLES  
 LASER CUT EDGES AND HOLES ( $\pm 0.010$ " ) - NO CONING OF HOLES  
 BENDS ARE  $\pm 1/2$  DEGREE  
 ALL OTHER MACHINING ( $\pm 0.030$ " )  
 ALL OTHER ASSEMBLY ( $\pm 0.060$ " )

PROPRIETARY NOTE:  
 THE DATA AND TECHNIQUES CONTAINED IN THIS DRAWING ARE PROPRIETARY INFORMATION OF VALMONT INDUSTRIES AND CONSIDERED A TRADE SECRET. ANY USE OR DISCLOSURE WITHOUT THE CONSENT OF VALMONT INDUSTRIES IS STRICTLY PROHIBITED.

DESCRIPTION  
**MONOPOLE TRIPLE T-ARM FOR 6 ANTENNAS**

CPD NO. 4543	DRAWN BY CEK 4/15/2011	ENG. APPROVAL
CLASS 81	SUB 01	DRAWING USAGE CUSTOMER
CHECKED BY BMC 4/28/2011		



Engineering Support Team:  
 1-888-753-7446

Locations:  
 New York, NY  
 Atlanta, GA  
 Los Angeles, CA  
 Plymouth, IN  
 Salem, OR  
 Dallas, TX

PART NO. **SEE "ASSEMBLY NO."**  
 DWG. NO. **RMV5-3XXX**

A	REMOVE FLATWASHERS FROM ARM TO CLAMP RING CONNECTION	CPD	BY	DATE
REV	DESCRIPTION OF REVISIONS	CPD	BY	DATE
REVISION HISTORY				