

VIEW A-A

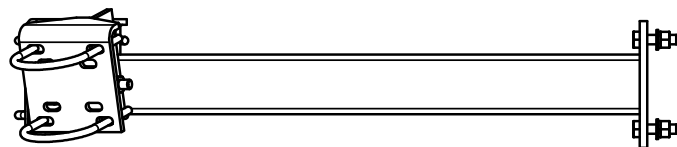

4" TO 4-1/2"
O.D. PIPE
(ORDERED SEPARATELY)

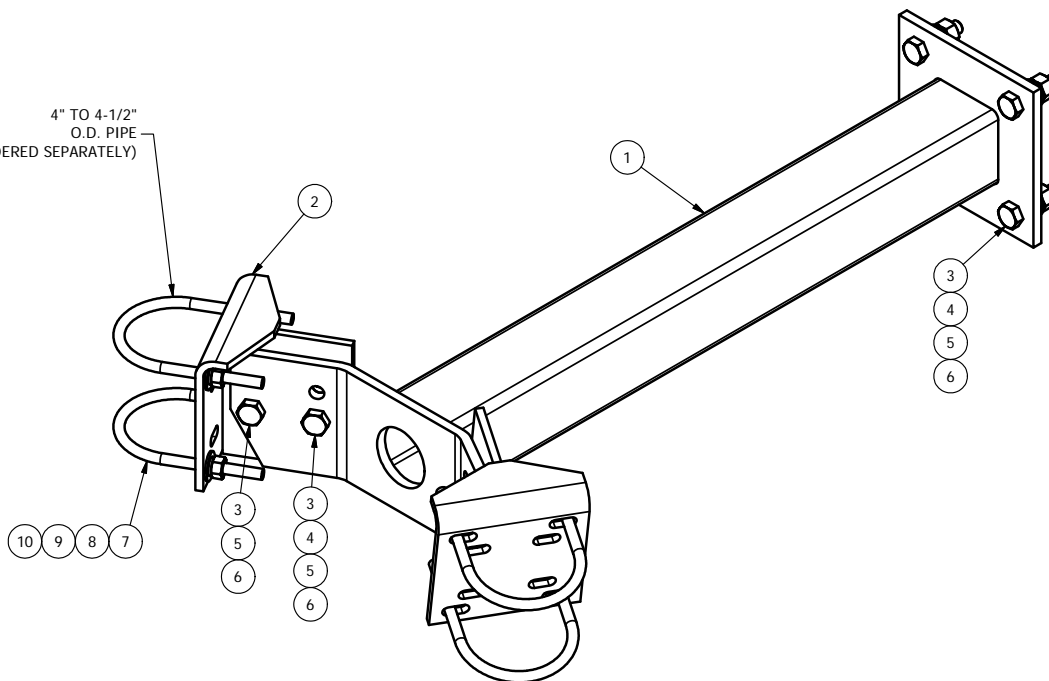

PARTS LIST						
ITEM	QTY	PART NO.	PART DESCRIPTION	LENGTH	UNIT WT.	NET WT.
1	1	X-99043	SA2-24 MAIN STANDOFF BRACKET		48.94	48.94
2	2	X-ATB	PIPE ATTACHMENT BRACKET		10.68	21.37
3	8	A582112	5/8" x 2-1/2" HDG A325 HEX BOLT	2.5 in.	0.33	2.67
4	6	A58FW	5/8" HDG A325 FLATWASHER		0.03	0.20
5	8	G58LW	5/8" HDG LOCKWASHER		0.03	0.21
6	8	A58NUT	5/8" HDG A325 HEX NUT		0.13	1.04
7	4	X-UB1418	1/2" X 4-1/8" X 6" X 3" UBOLT (HDG.)		0.84	3.36
7	4	X-UB1458	1/2" X 4-5/8" X 7" X 3" U-BOLT (HDG.)		0.97	3.89
8	8	G12FW	1/2" HDG USS FLATWASHER		0.03	0.27
9	8	G12LW	1/2" HDG LOCKWASHER		0.01	0.11
10	8	G12NUT	1/2" HDG HEAVY 2H HEX NUT		0.07	0.57
TOTAL WT. #						81.62

TOLERANCE NOTE

TOLERANCES ON DIMENSIONS, UNLESS OTHERWISE NOTED ARE:
 SAWED, SHEARED AND GAS CUT EDGES ($\pm 0.030"$)
 DRILLED AND GAS CUT HOLES ($\pm 0.030"$) - NO CONING OF HOLES
 LASER CUT EDGES AND HOLES ($\pm 0.010"$) - NO CONING OF HOLES
 BENDS ARE $\pm 1/2$ DEGREE - ALL OTHER MACHINING ($\pm 0.030"$)
 ALL OTHER ASSEMBLY ($\pm 0.060"$)

PROPRIETARY NOTE

THE DATA AND TECHNIQUES CONTAINED IN THIS DRAWING ARE PROPRIETARY INFORMATION OF VALMONT INDUSTRIES AND CONSIDERED A TRADE SECRET. ANY USE OR DISCLOSURE WITHOUT THE CONSENT OF VALMONT INDUSTRIES IS STRICTLY PROHIBITED.

DESCRIPTION

STANDOFF ARM
FOR TWO
ANTENNA PIPES

DRAWN BY

CEK 1/19/2011

CPD NO.

4779

DRAWING USAGE

CUSTOMER

ENG. APPROVAL

CHECKED BY

BMC 2/18/2011

SITE PRO 1
 A valmont COMPANY
 Engineering Support Team:
 1-888-753-7446
 Locations:
 New York, NY
 Atlanta, GA
 Los Angeles, CA
 Plymouth, IN
 Salem, OR
 Dallas, TX

PART NO.

SA4-24

DWG. NO.

SA4-24