

PARTS LIST						
ITEM	QTY	PART NO.	PART DESCRIPTION	LENGTH	UNIT WT.	NET WT.
1	1	SCX2	CROSSOVER PLATE	7 in	4.80	4.80
2	2	X-UB1300	1/2" X 3" X 5" X 2" U-BOLT (HDG.)		0.66	1.31
3	8	G12FW	1/2" HDG USS FLATWASHER		0.03	0.27
4	8	G12LW	1/2" HDG LOCKWASHER		0.01	0.11
5	8	G12NUT	1/2" HDG HEAVY 2H HEX NUT		0.07	0.57
6	2	X-UB1212	1/2" X 2-1/2" X 4-1/2" X 2" U-BOLT (HDG.)		0.63	1.25
					TOTAL WT. #	8.39

2-7/8" O.D. ANTENNA PIPE
(ORDERED SEPARATELY)

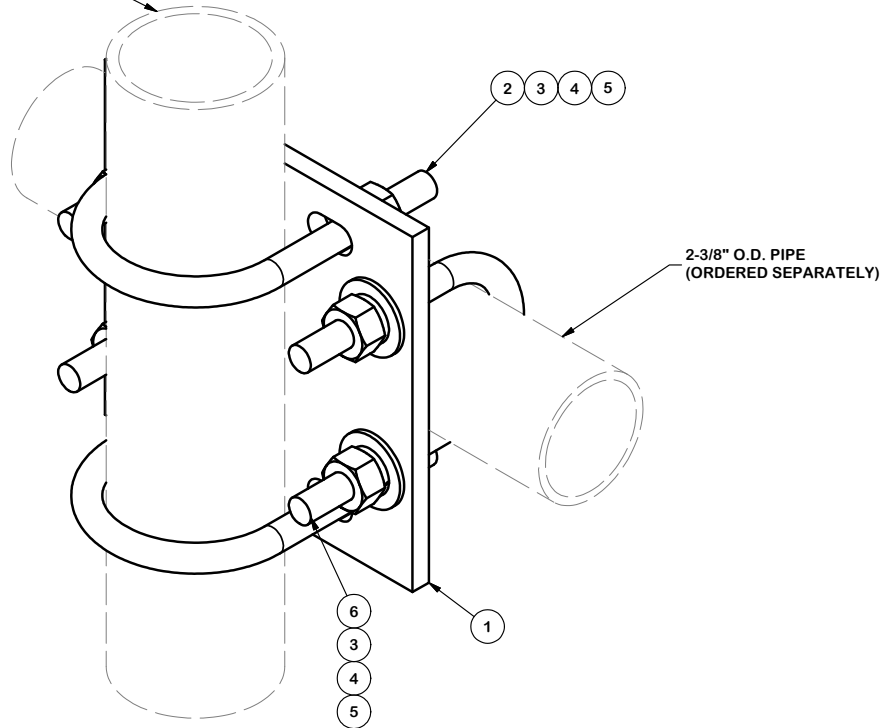

2-3/8" O.D. PIPE
(ORDERED SEPARATELY)

TOLERANCE NOTES

TOLERANCES ON DIMENSIONS, UNLESS OTHERWISE NOTED ARE:
 SAWED, SHEARED AND GAS CUT EDGES ($\pm 0.030"$)
 DRILLED AND GAS CUT HOLES ($\pm 0.030"$) - NO CONING OF HOLES
 LASER CUT EDGES AND HOLES ($\pm 0.010"$) - NO CONING OF HOLES
 BENDS ARE $\pm 1/2$ DEGREE
 ALL OTHER MACHINING ($\pm 0.030"$)
 ALL OTHER ASSEMBLY ($\pm 0.060"$)

PROPRIETARY NOTE:
 THE DATA AND TECHNIQUES CONTAINED IN THIS DRAWING ARE PROPRIETARY INFORMATION OF VALMONT INDUSTRIES AND CONSIDERED A TRADE SECRET. ANY USE OR DISCLOSURE WITHOUT THE CONSENT OF VALMONT INDUSTRIES IS STRICTLY PROHIBITED.

DESCRIPTION		CROSSOVER PLATE KIT	
-------------	--	---------------------	--

 A valmont COMPANY	Engineering Support Team: 1-888-753-7446	Locations: New York, NY Atlanta, GA Los Angeles, CA Plymouth, IN Salem, OR Dallas, TX
	PART NO. SCX2-K	

CPD NO.	DRAWN BY CEK 6/30/2011	ENG. APPROVAL
CLASS	DRAWING USAGE SHOP	CHECKED BY BMC 7/1/2011

DWG. NO.	SCX2-K
----------	--------