

PARTS LIST						
ITEM	QTY	PART NO.	PART DESCRIPTION	LENGTH	UNIT WT.	NET WT.
1	3	X-LWRM	RING MOUNT WELDMENT		68.81	206.42
2	3	X-SNP-STL	SNB8 TELESCOPING ARM FOR GRATING		105.60	316.79
3	3	X-SNPC	CORNER GRATING WELDMENT		194.26	582.77
4	3	P3150	3-1/2" X 150" SCH 40 GALVANIZED PIPE	150.000 in	94.80	284.40
5	3	X-SNPP1G	CLAMP PLATE	7.000 in	2.03	6.10
6	9	X-SP219	SMALL SUPPORT CROSS PLATE	8.250 in	8.61	77.50
7	9	G58R-48	5/8" x 48" THREADED ROD (HDG.)		0.55	4.94
7	9	G58R-24	5/8" x 24" THREADED ROD (HDG.)		0.55	4.94
8	12	A58234	5/8" x 2-3/4" HDG A325 HEX BOLT	2.75	0.36	4.27
9	30	A58FW	5/8" HDG A325 FLATWASHER		0.03	1.02
10	42	G58LW	5/8" HDG LOCKWASHER		0.03	1.10
11	18	A58NUT	5/8" HDG A325 HEX NUT		0.13	2.34
12	24	G58NUT	5/8" HDG HEAVY 2H HEX NUT		0.13	3.12
13	18	X-UB1306	1/2" X 3-5/8" X 6" X 3" U-BOLT (HDG.)		0.73	13.17
14	12	X-UB1358	1/2" X 3-5/8" X 5-1/2" X 3" U-BOLT (HDG.)		0.73	8.78
15	18	X-UB1212	1/2" X 2-1/2" X 4-1/2" X 2" U-BOLT (HDG.)		0.73	13.17
16	6	G12065	1/2" x 6-1/2" HDG HEX BOLT GR5 FULL THREAD	7-1/2	0.41	2.46
17	96	G12FW	1/2" HDG USS FLATWASHER		0.03	3.27
18	102	G12LW	1/2" HDG LOCKWASHER		0.01	1.42
19	102	G12NUT	1/2" HDG HEAVY 2H HEX NUT		0.07	7.31
20	3	X-SNPM	GRATING WALKWAY FOR 12' & 14' SNUB NOSE PLATFORM		82.72	248.15
21	24	G58FW	5/8" HDG USS FLATWASHER		0.07	1.69
22	12	G5802	5/8" x 2" HDG HEX BOLT GR5		0.27	3.24
23	9	A	2" SCH. 40 PIPE (2.375" O.D. x 0.154" WALL) A500	B	C	D

2-3/8" O.D. VERTICAL MOUNTING PIPES					
ASSEMBLY NO.	PART NO. "A"	LENGTH "B"	UNIT WEIGHT "C"	NET WEIGHT "D"	TOTAL WEIGHT
SNP12-384	P284	7'-0"	26.91	242.19	1862.68
SNP12-396	P296	8'-0"	30.76	276.84	1897.33
SNP12-3126	P2126	10'-6"	40.75	366.75	1987.24

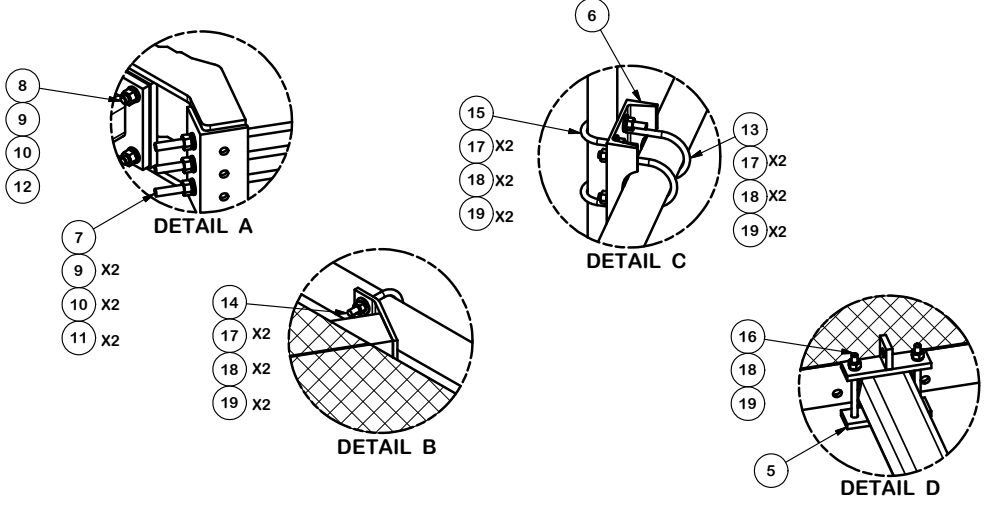

TOLERANCE NOTES
 TOLERANCES ON DIMENSIONS, UNLESS OTHERWISE NOTED ARE:
 SAWED, SHEARED AND GAS CUT EDGES ($\pm 0.030"$)
 DRILLED AND GAS CUT HOLES ($\pm 0.030"$) - NO CONING OF HOLES
 LASER CUT EDGES AND HOLES ($\pm 0.010"$) - NO CONING OF HOLES
 BENDS ARE $\pm 1/2$ DEGREE
 ALL OTHER MACHINING ($\pm 0.030"$)
 ALL OTHER ASSEMBLY ($\pm 0.060"$)

PROPRIETARY NOTE:
 THE DATA AND TECHNIQUES CONTAINED IN THIS DRAWING ARE PROPRIETARY INFORMATION OF VALMONT INDUSTRIES AND CONSIDERED A TRADE SECRET. ANY USE OR DISCLOSURE WITHOUT THE CONSENT OF VALMONT INDUSTRIES IS STRICTLY PROHIBITED.

DESCRIPTION	
12' SNUB NOSE PLATFORM	
CPD NO.	DRAWN BY
	CEK 12/30/2014
CLASS	ENG. APPROVAL
81	17/2015
SUB	CHECKED BY
02	BMC
DRAWING USAGE	
CUSTOMER	

 A valmont COMPANY	Locations: New York, NY Atlanta, GA Los Angeles, CA Plymouth, IN Salem, OR Dallas, TX
	Engineering Support Team: 1-888-753-7446
PART NO.	SEE ASSEMBLY NO.
DWG. NO.	SNP12-3XX

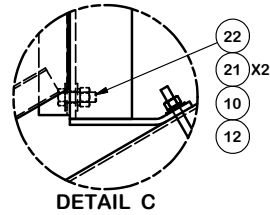
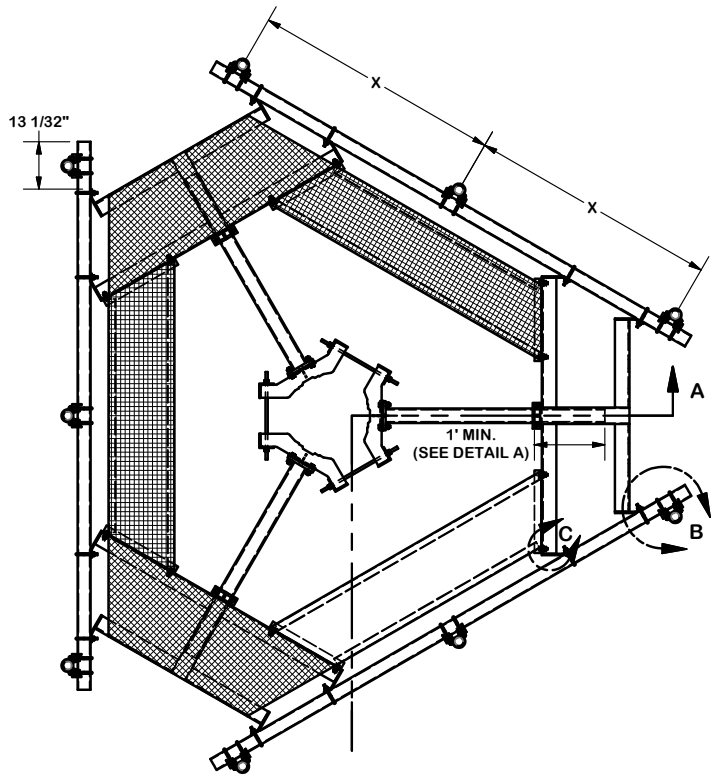

DETAIL C

NOTE:
GRATING REMOVED
FOR CLARITY

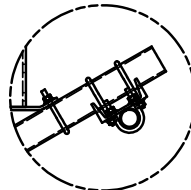

DETAIL B

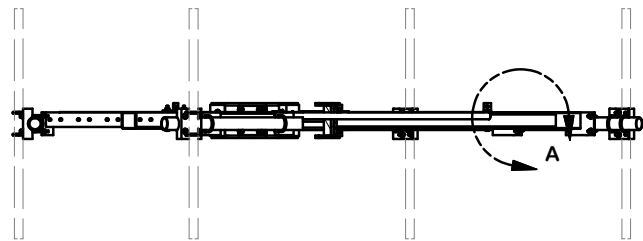
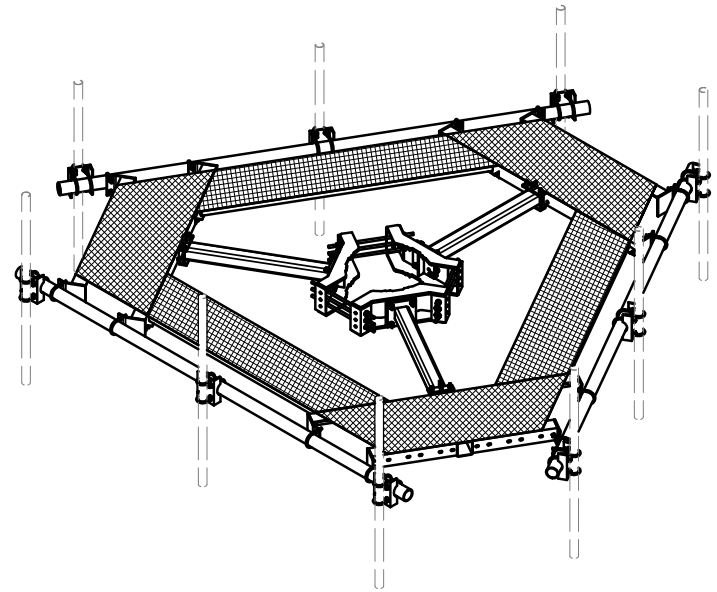

SECTION A-A

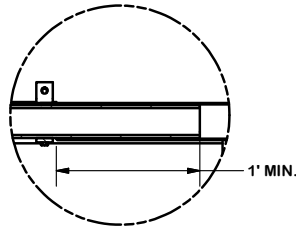

DETAIL A

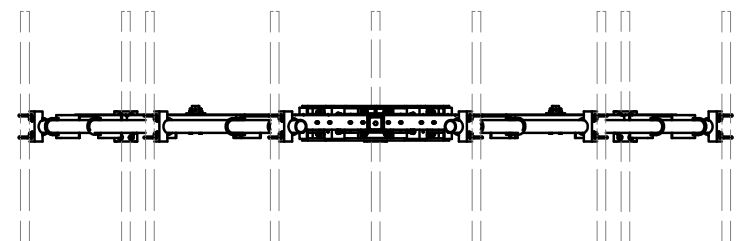

TOLERANCE NOTES

TOLERANCES ON DIMENSIONS, UNLESS OTHERWISE NOTED ARE:
 SAWED, SHEARED AND GAS CUT EDGES ($\pm 0.030"$)
 DRILLED AND GAS CUT HOLES ($\pm 0.030"$) - NO CONING OF HOLES
 LASER CUT EDGES AND HOLES ($\pm 0.010"$) - NO CONING OF HOLES
 BENDS ARE $\pm 1/2$ DEGREE
 ALL OTHER MACHINING ($\pm 0.030"$)
 ALL OTHER ASSEMBLY ($\pm 0.060"$)

PROPRIETARY NOTE:
 THE DATA AND TECHNIQUES CONTAINED IN THIS DRAWING ARE PROPRIETARY INFORMATION OF VALMONT INDUSTRIES AND CONSIDERED A TRADE SECRET. ANY USE OR DISCLOSURE WITHOUT THE CONSENT OF VALMONT INDUSTRIES IS STRICTLY PROHIBITED.

DESCRIPTION
12' SNUB NOSE PLATFORM

SITE PRO 1
 Engineering Support Team:
 1-888-753-7446
 Locations:
 New York, NY
 Atlanta, GA
 Los Angeles, CA
 Plymouth, IN
 Salem, OR
 Dallas, TX

CPD NO.	DRAWN BY	ENG. APPROVAL
CLASS	DRAWING USAGE	CHECKED BY
81	CUSTOMER	BMC 1/7/2015

PART NO.	SEE ASSEMBLY NO.	PAGE
DWG. NO.	SNP12-3XX	2 OF 2