

PARTS LIST						
ITEM	QTY	PART NO.	PART DESCRIPTION	LENGTH	UNIT WT.	NET WT.
1	3	X-LWRM	RING MOUNT WELDMENT		68.81	206.42
2	3	X-SNP-STL	SNB8 TELESCOPING ARM FOR GRATING		105.60	316.79
3	3	X-SNPC	CORNER GRATING WELDMENT		194.26	582.77
4	3	P3174	3-1/2" X 174" SCH 40 GALVANIZED PIPE	174.000 in	109.97	329.90
5	3	X-SNPP1G	CLAMP PLATE	7.000 in	2.03	6.10
6	12	X-SP219	SMALL SUPPORT CROSS PLATE	8.250 in	8.61	103.33
7	9	G58R-48	5/8" x 48" THREADED ROD (HDG.)		0.55	4.94
7	9	G58R-24	5/8" x 24" THREADED ROD (HDG.)		0.55	4.94
8	12	A58234	5/8" x 2-3/4" HDG A325 HEX BOLT	2.75	0.36	4.27
9	30	A58FW	5/8" HDG A325 FLATWASHER		0.03	1.02
10	42	G58LW	5/8" HDG LOCKWASHER		0.03	1.10
11	18	A58NUT	5/8" HDG A325 HEX NUT		0.13	2.34
12	24	G58NUT	5/8" HDG HEAVY 2H HEX NUT		0.13	3.12
13	24	X-UB1306	1/2" X 3-5/8" X 6" X 3" U-BOLT (HDG.)		0.73	17.56
14	12	X-UB1358	1/2" X 3-5/8" X 5-1/2" X 3" U-BOLT (HDG.)		0.73	8.78
15	24	X-UB1212	1/2" X 2-1/2" X 4-1/2" X 2" U-BOLT (HDG.)		0.73	17.56
16	6	G12065	1/2" x 6-1/2" HDG HEX BOLT GR5 FULL THREAD	7-1/2	0.41	2.46
17	120	G12FW	1/2" HDG USS FLATWASHER		0.03	4.09
18	126	G12LW	1/2" HDG LOCKWASHER		0.01	1.75
19	126	G12NUT	1/2" HDG HEAVY 2H HEX NUT		0.07	9.02
20	3	X-SNPM	GRATING WALKWAY FOR 12' & 14' SNUB NOSE PLATFORM		82.72	248.15
21	24	G58FW	5/8" HDG USS FLATWASHER		0.07	1.69
22	12	G5802	5/8" x 2" HDG HEX BOLT GR5		0.27	3.24
23	9	A	2" SCH. 40 PIPE (2.375" O.D. x 0.154" WALL) A500	B	C	D

2-3/8" O.D. VERTICAL MOUNTING PIPES					
ASSEMBLY NO.	PART NO. "A"	LENGTH "B"	UNIT WEIGHT "C"	NET WEIGHT "D"	TOTAL WEIGHT
SNP14-484	P284	7'-0"	26.91	322.92	1988.91
SNP14-496	P296	8'-0"	30.76	369.12	1942.83
SNP14-4126	P2126	10'-6"	40.75	489.00	2154.99

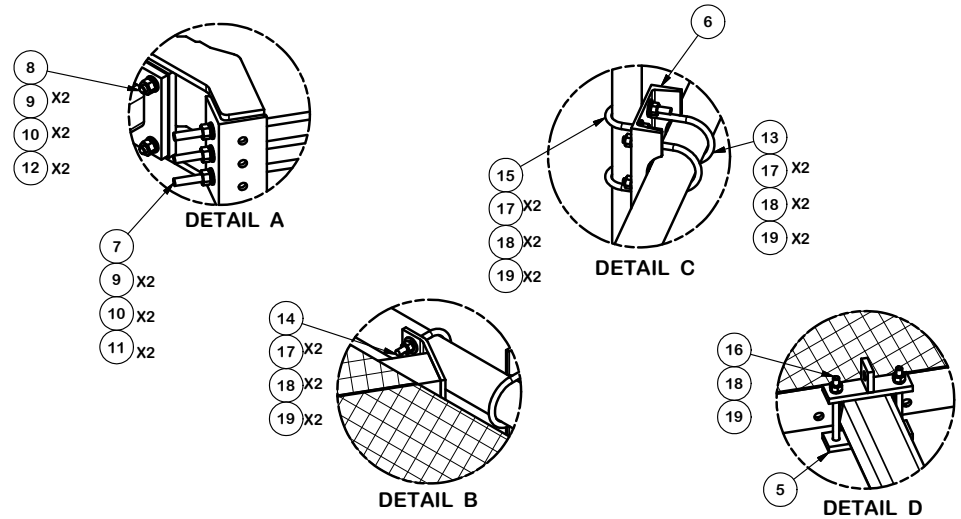

TOLERANCE NOTES

TOLERANCES ON DIMENSIONS, UNLESS OTHERWISE NOTED ARE:
 SAWED, SHEARED AND GAS CUT EDGES ($\pm 0.030"$)
 DRILLED AND GAS CUT HOLES ($\pm 0.030"$) - NO CONING OF HOLES
 LASER CUT EDGES AND HOLES ($\pm 0.010"$) - NO CONING OF HOLES
 BENDS ARE $\pm 1/2$ DEGREE
 ALL OTHER MACHINING ($\pm 0.030"$)
 ALL OTHER ASSEMBLY ($\pm 0.060"$)

PROPRIETARY NOTE:
 THE DATA AND TECHNIQUES CONTAINED IN THIS DRAWING ARE PROPRIETARY INFORMATION OF VALMONT INDUSTRIES AND CONSIDERED A TRADE SECRET. ANY USE OR DISCLOSURE WITHOUT THE CONSENT OF VALMONT INDUSTRIES IS STRICTLY PROHIBITED.

DESCRIPTION
14' SNUB NOSE PLATFORM

CPD NO.	DRAWN BY	ENG. APPROVAL
CLASS	CEK 12/19/2014	CHECKED BY
81	SUB 02	BMC 1/7/2015
DRAWING USAGE		CUSTOMER

SITE PRO 1
 A valmont COMPANY
 Engineering Support Team:
 1-888-753-7446
 Locations:
 New York, NY
 Atlanta, GA
 Los Angeles, CA
 Plymouth, IN
 Salem, OR
 Dallas, TX

PART NO.	SEE ASSEMBLY NO.	PAGE
DWG. NO.	SNP14-4XX	1 OF 2

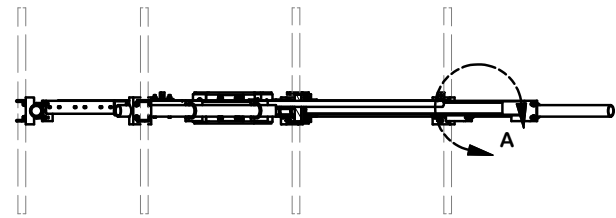
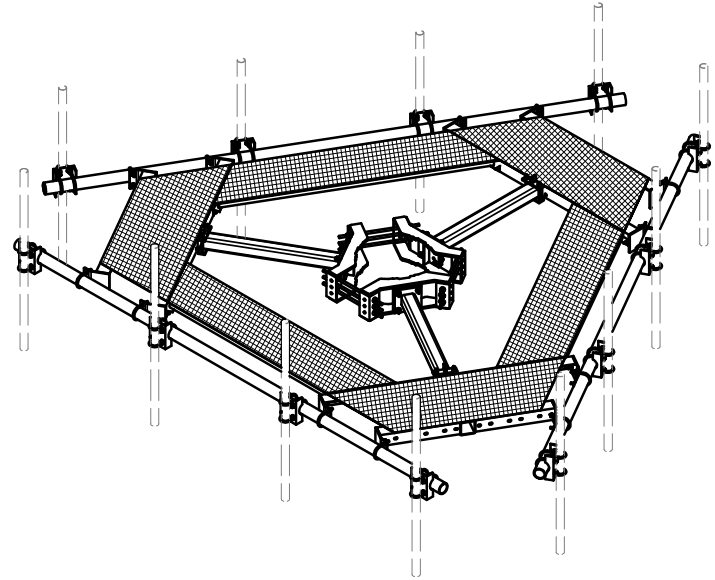
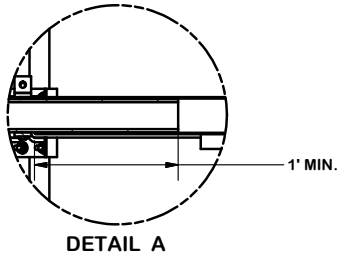
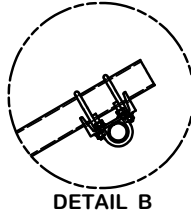
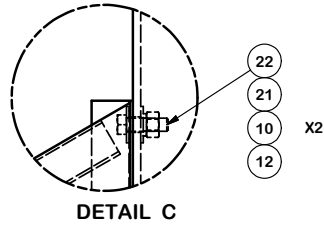
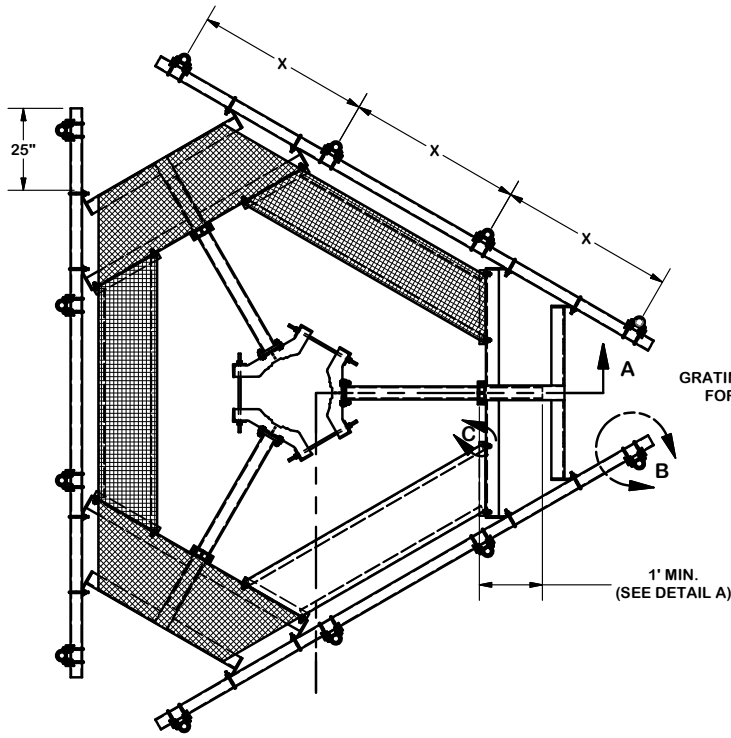

SECTION A-A

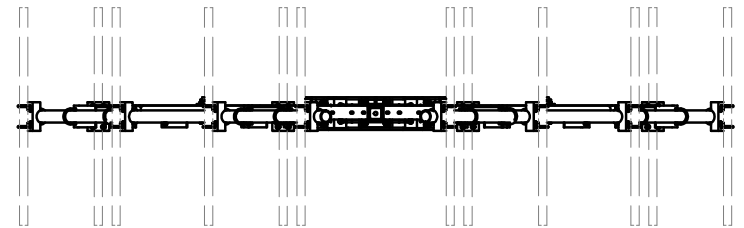

TOLERANCE NOTES

TOLERANCES ON DIMENSIONS, UNLESS OTHERWISE NOTED ARE:
 SAWED, SHEARED AND GAS CUT EDGES ($\pm 0.030"$)
 DRILLED AND GAS CUT HOLES ($\pm 0.030"$) - NO CONING OF HOLES
 LASER CUT EDGES AND HOLES ($\pm 0.010"$) - NO CONING OF HOLES
 BENDS ARE $\pm 1/2$ DEGREE
 ALL OTHER MACHINING ($\pm 0.030"$)
 ALL OTHER ASSEMBLY ($\pm 0.060"$)

PROPRIETARY NOTE:
 THE DATA AND TECHNIQUES CONTAINED IN THIS DRAWING ARE PROPRIETARY INFORMATION OF VALMONT INDUSTRIES AND CONSIDERED A TRADE SECRET. ANY USE OR DISCLOSURE WITHOUT THE CONSENT OF VALMONT INDUSTRIES IS STRICTLY PROHIBITED.

DESCRIPTION
14' SNUB NOSE PLATFORM

CPD NO.	DRAWN BY CEK 12/19/2014	ENG. APPROVAL
CLASS 81	SUB 02	DRAWING USAGE CUSTOMER
CHECKED BY BMC 1/7/2015		

SITE PRO 1
 A valmont COMPANY
 Engineering Support Team:
 1-888-753-7446
 Locations:
 New York, NY
 Atlanta, GA
 Los Angeles, CA
 Plymouth, IN
 Salem, OR
 Dallas, TX

PART NO.	SEE ASSEMBLY NO.	PAGE 2 OF 2
DWG. NO.	SNP14-4XX	