

PARTS LIST						
ITEM	QTY	PART NO.	PART DESCRIPTION	LENGTH	UNIT WT.	NET WT.
1	1	X-SP219	SMALL SUPPORT CROSS PLATE	8 1/4 in	8.61	8.61
2	2	X-UB1306	1/2" X 3-5/8" X 6" X 3" U-BOLT (HDG.)		0.66	1.31
3	2	X-UB1300	1/2" X 3" X 5" X 2" U-BOLT (HDG.)		0.66	1.31
4	8	G12FW	1/2" HDG USS FLATWASHER		0.03	0.27
5	8	G12LW	1/2" HDG LOCKWASHER		0.01	0.11
6	8	G12NUT	1/2" HDG HEAVY 2H HEX NUT		0.07	0.57
					TOTAL WT. #	12.61

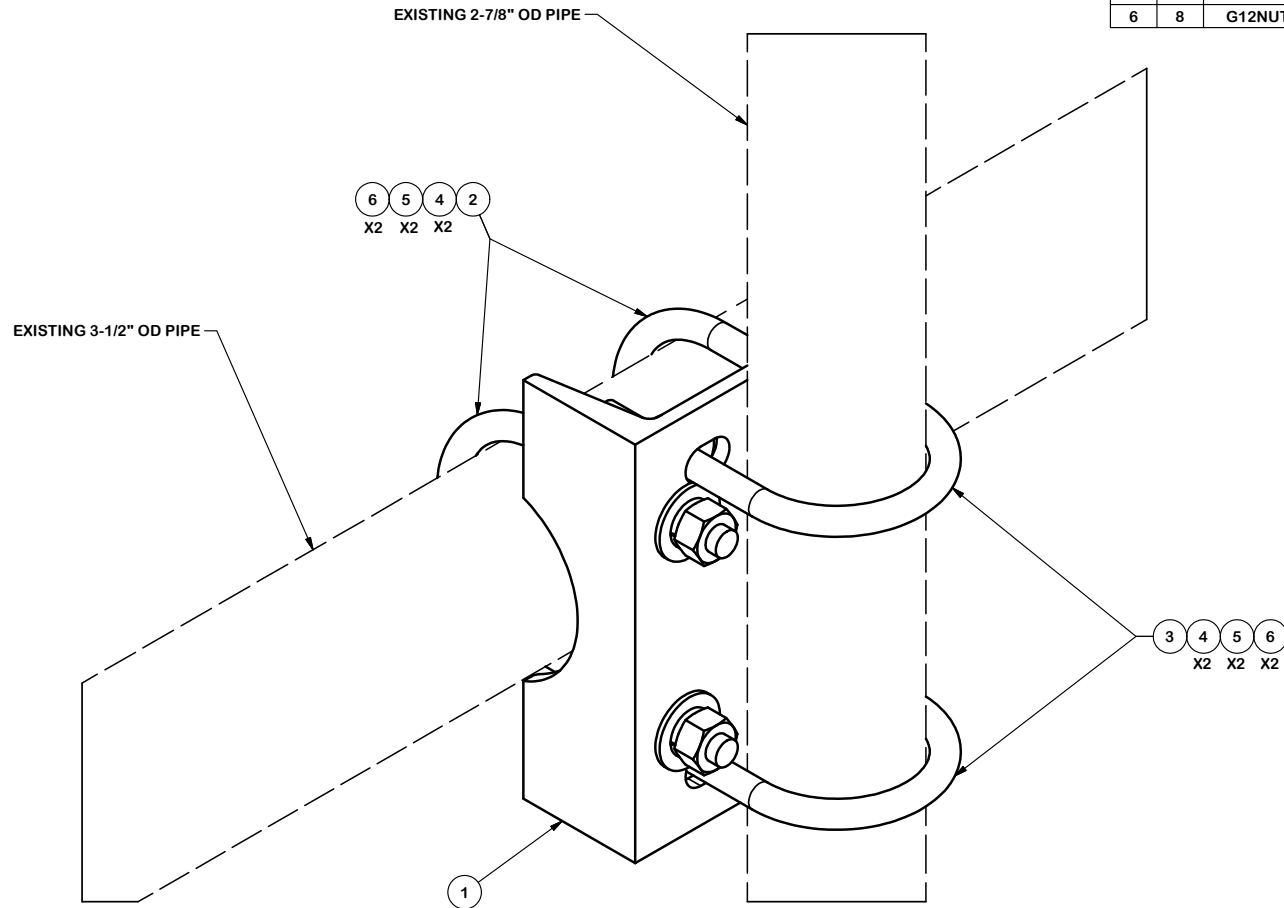

**TOLERANCE NOTES**

TOLERANCES ON DIMENSIONS, UNLESS OTHERWISE NOTED ARE:  
 SAWED, SHEARED AND GAS CUT EDGES ( $\pm 0.030"$ )  
 DRILLED AND GAS CUT HOLES ( $\pm 0.030"$ ) - NO CONING OF HOLES  
 LASER CUT EDGES AND HOLES ( $\pm 0.010"$ ) - NO CONING OF HOLES  
 BENDS ARE  $\pm 1/2$  DEGREE  
 ALL OTHER MACHINING ( $\pm 0.030"$ )  
 ALL OTHER ASSEMBLY ( $\pm 0.060"$ )

PROPRIETARY NOTE:  
 THE DATA AND TECHNIQUES CONTAINED IN THIS DRAWING ARE PROPRIETARY INFORMATION OF VALMONT INDUSTRIES AND CONSIDERED A TRADE SECRET. ANY USE OR DISCLOSURE WITHOUT THE CONSENT OF VALMONT INDUSTRIES IS STRICTLY PROHIBITED.

DESCRIPTION  
 2-7/8" TO 3-1/2"  
 PIPE MOUNT ASSEMBLY

**SITE PRO 1**  
 A valmont COMPANY  
 Locations:  
 New York, NY  
 Atlanta, GA  
 Los Angeles, CA  
 Plymouth, IN  
 Salem, OR  
 Dallas, TX  
 Engineering Support Team:  
 1-888-753-7446

REV	DESCRIPTION OF REVISIONS	CPD	BY	DATE
A	REDRAWN IN INV. UPDATED VIEWS & TABLE		KC8	8-21-2012

CPD NO.	4518	DRAWN BY	BMC	6/3/2009	ENG. APPROVAL
CLASS	81	SUB	01	DRAWING USAGE	CUSTOMER
			CHECKED BY	CEK	2/18/2013

PART NO.	SP219-H
DWG. NO.	SP219-H