

2-3/8" O.D. VERTICAL MOUNTING PIPES

ASSEMBLY "A"	PART NO. "B"	PART DESCRIPTION	LENGTH "C"	UNIT WT. "D"	NET WT. "E"	TOTAL WEIGHT
SP219-63	P263	2-3/8" DIA X 63" SCH 40 GALVANIZED PIPE	63"	20.18	20.18	32.65
SP219-72	P272	2-3/8" DIA X 63" SCH 40 GALVANIZED PIPE	72"	23.07	23.07	35.54
SP219-84	P284	2-3/8" DIA X 63" SCH 40 GALVANIZED PIPE	84"	26.91	26.91	39.38
SP219-96	P296	2-3/8" DIA X 63" SCH 40 GALVANIZED PIPE	96"	30.76	30.76	43.23
SP219-126	P2126	2-3/8" DIA X 10'-6" SCH 40 GALVANIZED PIPE	126"	40.37	40.37	52.84

PARTS LIST

ITEM	QTY	PART NO.	PART DESCRIPTION	LENGTH	UNIT WT.	NET WT.
1	1	X-SP219	SMALL SUPPORT CROSS PLATE	8.250 in	8.61	8.61
2	2	X-UB1306	1/2" X 3-5/8" X 6" X 3" U-BOLT (HDG.)		0.26	0.51
3	2	X-UB1212	1/2" X 2-1/2" X 4-1/2" X 2" U-BOLT (HDG.)		0.26	0.51
4	8	G12NUT	1/2" HDG HEAVY 2H HEX NUT		0.07	0.57
5	8	G12LW	1/2" HDG LOCKWASHER	.125	0.01	0.11
6	8	G12FW	1/2" HDG USS FLATWASHER	0.095	0.03	0.27
7	1	"B"	2-3/8" O.D. VERTICAL MOUNTING PIPES	"C"	"D"	"E"

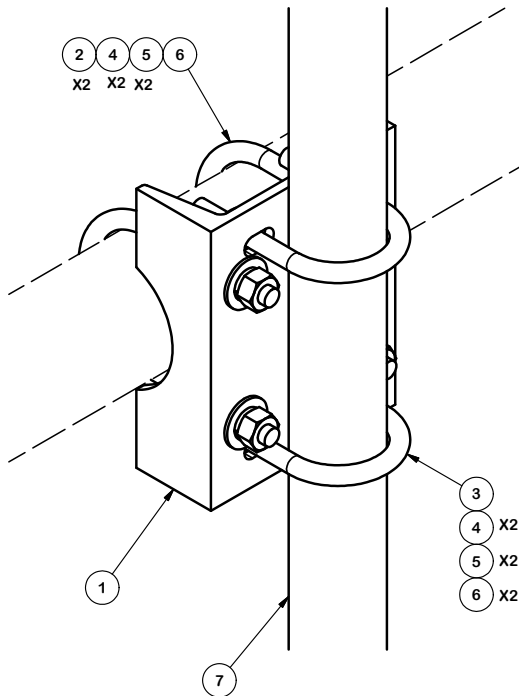

FINISH:
HOT DIP GALVANIZED.

TOLERANCE NOTES

TOLERANCES ON DIMENSIONS, UNLESS OTHERWISE NOTED ARE:
 SAWED, SHEARED AND GAS CUT EDGES ($\pm 0.030"$)
 DRILLED AND GAS CUT HOLES ($\pm 0.030"$) - NO CONING OF HOLES
 LASER CUT EDGES AND HOLES ($\pm 0.010"$) - NO CONING OF HOLES
 BENDS ARE $\pm 1/2$ DEGREE
 ALL OTHER MACHINING ($\pm 0.030"$)
 ALL OTHER ASSEMBLY ($\pm 0.060"$)

PROPRIETARY NOTE:
 THE DATA AND TECHNIQUES CONTAINED IN THIS DRAWING ARE PROPRIETARY INFORMATION OF VALMONT INDUSTRIES AND CONSIDERED A TRADE SECRET. ANY USE OR DISCLOSURE WITHOUT THE CONSENT OF VALMONT INDUSTRIES IS STRICTLY PROHIBITED.

DESCRIPTION
 PIPE MOUNT KITS

SITE PRO 1
 Engineering Support Team:
 1-888-753-7446
 Locations:
 New York, NY
 Atlanta, GA
 Los Angeles, CA
 Plymouth, IN
 Salem, OR
 Dallas, TX

REV	DESCRIPTION OF REVISIONS	CPD	BY	DATE
A	UPDATED DRAWING, MADE NEW DRAWING FOR SP219-xxxH		CEK	1/25/2016

CPD NO.	DRAWN BY	ENG. APPROVAL
	KC8 8/8/2012	
CLASS	SUB	DRAWING USAGE
81	01	CUSTOMER

PART NO.	DWG. NO.
SEE ASSEMBLY "A"	SP219-xxx