

| PARTS LIST | | | | | | |
|------------|-----|----------|--------------------------------|----------|-------------|---------|
| ITEM | QTY | PART NO. | PART DESCRIPTION | LENGTH | UNIT WT. | NET WT. |
| 1 | 1 | X-SP507 | FORMED PIPE HEAD PLATE | | 11.26 | 11.26 |
| 2 | 1 | X-SP508 | PIPE HEAD WELDMENT | | 18.71 | 18.71 |
| 3 | 2 | G12112 | 1/2" x 1-1/2" HDG HEX BOLT GR5 | 1 1/2 in | 0.15 | 0.30 |
| 4 | 3 | G1201 | 1/2" x 1" HDG HEX BOLT GR5 | 1 in | 0.12 | 0.36 |
| 5 | 2 | X-JB8 | 3/8" X 8"L X 6" TH J-BOLT | | 0.33 | 0.66 |
| 6 | 2 | G38FW | 3/8" HDG USS FLATWASHER | | 0.01 | 0.02 |
| 7 | 2 | G38LW | 3/8" HDG LOCKWASHER | | 0.01 | 0.01 |
| 8 | 2 | G38NUT | 3/8" HDG HEAVY 2H HEX NUT | | 0.03 | 0.07 |
| | | | | | TOTAL WT. # | 31.39 |

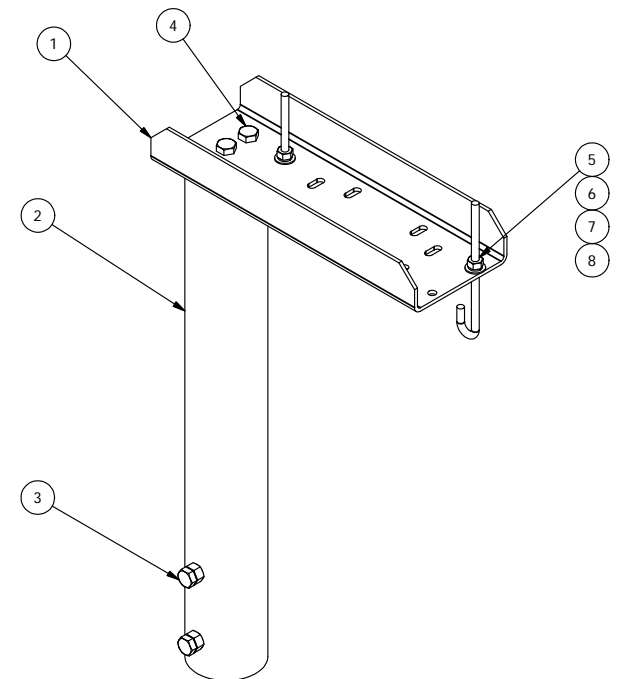

TOLERANCE NOTES

**TOLERANCES ON DIMENSIONS, UNLESS OTHERWISE NOTED ARE:
 SAWED, SHEARED AND GAS CUT EDGES ($\pm 0.030"$)
 DRILLED AND GAS CUT HOLES ($\pm 0.030"$) - NO CONING OF HOLES
 LASER CUT EDGES AND HOLES ($\pm 0.010"$) - NO CONING OF HOLES
 BENDS ARE $\pm 1/2$ DEGREE
 ALL OTHER MACHINING ($\pm 0.030"$)
 ALL OTHER ASSEMBLY ($\pm 0.060"$)**

**PROPRIETARY NOTE:
 THE DATA AND TECHNIQUES CONTAINED IN THIS DRAWING ARE PROPRIETARY INFORMATION OF VALMONT
 INDUSTRIES AND CONSIDERED A TRADE SECRET. ANY USE OR DISCLOSURE WITHOUT THE CONSENT OF
 VALMONT INDUSTRIES IS STRICTLY PROHIBITED.**

DESCRIPTION
**UNIVERSAL PIPE HEAD
 GALVANIZED**



Locations:
 New York, NY
 Atlanta, GA
 Los Angeles, CA
 Plymouth, IN
 Salem, OR
 Dallas, TX
 Engineering Support Team:
 1-888-753-7446

| | | |
|---------|------------|---------------|
| CPD NO. | DRAWN BY | ENG. APPROVAL |
| 81 | KC8 | 5/29/2012 |
| CLASS | SUB | DRAWING USAGE |
| 81 | 01 | CUSTOMER |
| | CHECKED BY | |
| | CEK | 7/9/2012 |

| | |
|----------|-------|
| PART NO. | SP509 |
| DWG. NO. | SP509 |