

PARTS LIST						
ITEM	QTY	PART NO.	PART DESCRIPTION	LENGTH	UNIT WT.	NET WT.
1	2	SCX4	CROSSOVER PLATE	8 1/2 in	6.02	12.04
2	4	X-116165	3" V-CLAMP		0.74	2.97
3	4	X-UB1458	1/2" X 4-5/8" X 7" X 3" GALV U-BOLT		0.97	3.89
4	40	G12FW	1/2" HDG USS FLATWASHER		0.03	1.36
5	24	G12LW	1/2" HDG LOCKWASHER		0.01	0.33
6	24	G12NUT	1/2" HDG HEAVY 2H HEX NUT		0.07	1.72
7	8	G12045	1/2" x 4.5" HDG HEX BOLT GR5 FULL THREAD	4 1/2 in	0.30	2.38
8	8	G12065	1/2" x 6-1/2" HDG HEX BOLT GR5 FULL THREAD	6 1/2 in	0.41	3.28
9	4	X-115765	5" V-CLAMP		1.02	4.07
					<b>TOTAL WT. #</b>	<b>32.05</b>

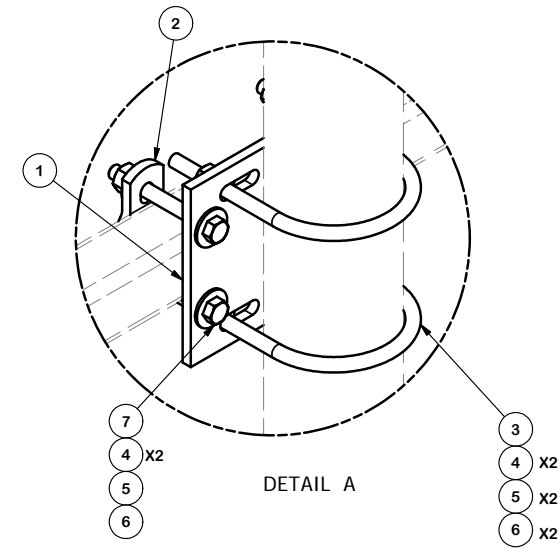

**TOLERANCE NOTES**  
 TOLERANCES ON DIMENSIONS, UNLESS OTHERWISE NOTED ARE:  
 SAWED, SHEARED AND GAS CUT EDGES ( $\pm 0.030"$ )  
 DRILLED AND GAS CUT HOLES ( $\pm 0.030"$ ) - NO CONING OF HOLES  
 LASER CUT EDGES AND HOLES ( $\pm 0.010"$ ) - NO CONING OF HOLES  
 BENDS ARE  $\pm 1/2$  DEGREE  
 ALL OTHER MACHINING ( $\pm 0.030"$ )  
 ALL OTHER ASSEMBLY ( $\pm 0.060"$ )

PROPRIETARY NOTE:  
 THE DATA AND TECHNIQUES CONTAINED IN THIS DRAWING ARE PROPRIETARY INFORMATION OF VALMONT INDUSTRIES AND CONSIDERED A TRADE SECRET. ANY USE OR DISCLOSURE WITHOUT THE CONSENT OF VALMONT INDUSTRIES IS STRICTLY PROHIBITED.

DESCRIPTION		PIPE ,PUNT FOR TUBULAR ARM PIPE MOUNT	
CPD NO.	DRAWN BY	ENG. APPROVAL	
semb	CEK 9/8/2011		
CLASS	DRAWING USAGE	CHECKED BY	
81	01 CUSTOMER	BMC 9/9/2011	

 <b>A valmont COMPANY</b>	Locations: New York, NY Atlanta, GA Los Angeles, CA Plymouth, IN Salem, OR Dallas, TX
	Engineering Support Team: 1-888-753-7446
PART NO.	TAP-PM
DWG. NO.	TAP-PM