

PARTS LIST						
ITEM	QTY	PART NO.	PART DESCRIPTION	LENGTH	UNIT WT.	NET WT.
1	4	X-UQB4	QUAD BRACKET WELDMENT		61.57	246.27
2	24	G58FW	5/8" HDG USS FLATWASHER	1/8 in	0.07	1.69
3	24	G58LW	5/8" HDG LOCKWASHER		0.03	0.63
4	24	G58NUT	5/8" HDG HEAVY 2H HEX NUT		0.13	3.12
5	12	G58R-48	5/8" X 48" THREADED ROD (HDG.)		4.43	53.19
6	12	G58R-24	5/8" X 24" THREADED ROD (HDG.)		2.22	26.60
TOTAL WT. #						351.38

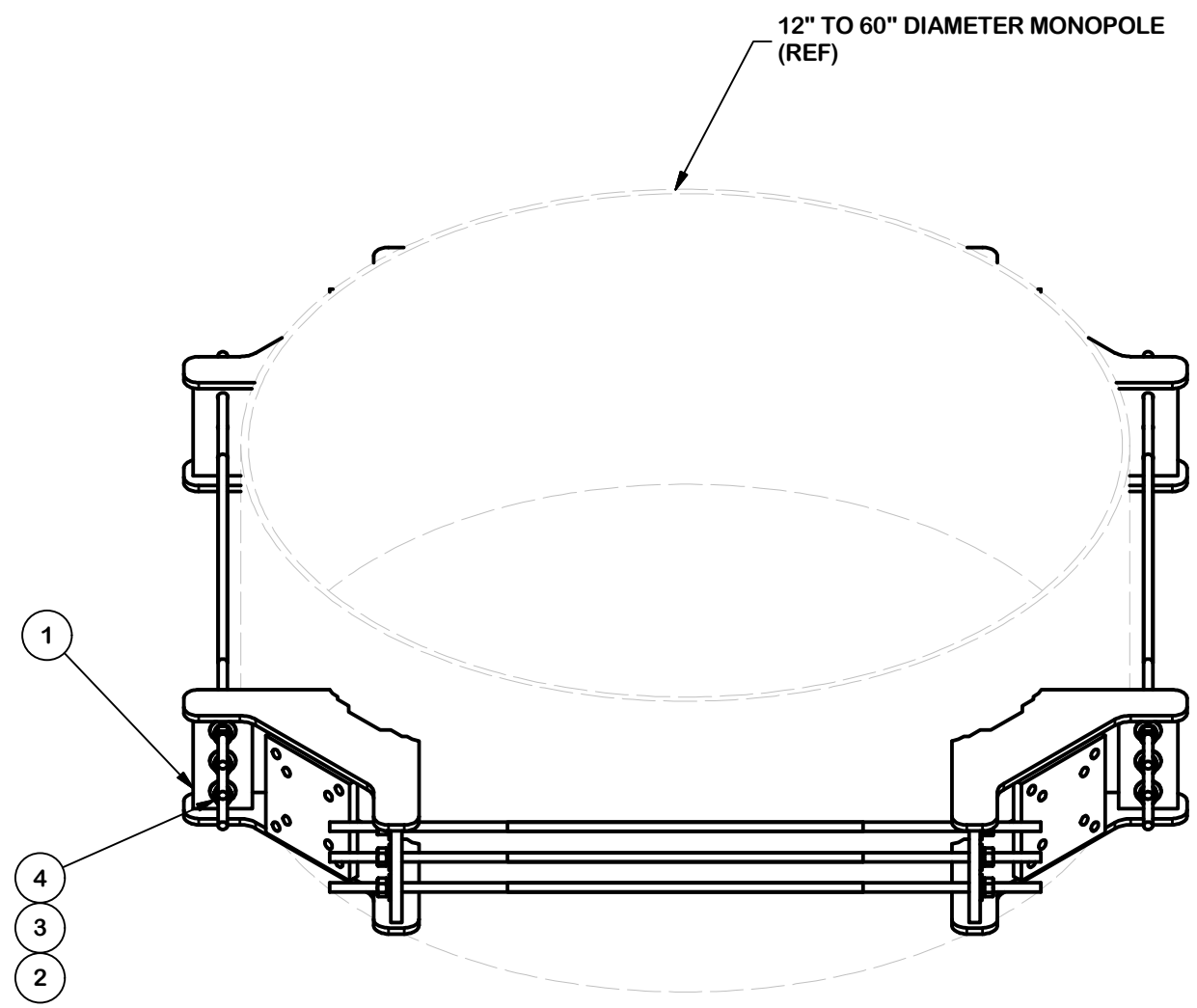

TOLERANCE NOTES

TOLERANCES ON DIMENSIONS, UNLESS OTHERWISE NOTED ARE:
 SAWED, SHEARED AND GAS CUT EDGES ($\pm 0.030"$)
 DRILLED AND GAS CUT HOLES ($\pm 0.030"$) - NO CONING OF HOLES
 LASER CUT EDGES AND HOLES ($\pm 0.010"$) - NO CONING OF HOLES
 BENDS ARE $\pm 1/2$ DEGREE
 ALL OTHER MACHINING ($\pm 0.030"$)
 ALL OTHER ASSEMBLY ($\pm 0.060"$)

PROPRIETARY NOTE:
 THE DATA AND TECHNIQUES CONTAINED IN THIS DRAWING ARE PROPRIETARY INFORMATION OF VALMONT INDUSTRIES AND CONSIDERED A TRADE SECRET. ANY USE OR DISCLOSURE WITHOUT THE CONSENT OF VALMONT INDUSTRIES IS STRICTLY PROHIBITED.

DESCRIPTION
**QUAD UNIVERSAL RING MOUNT
 FOR POLES 12" TO 60"
 (UQB4)**

CPD NO. 4893	DRAWN BY CEK 9/20/2010	ENG. APPROVAL
CLASS 81	SUB 01	DRAWING USAGE CUSTOMER
CHECKED BY BMC 9/20/2010		

SITE PRO 1
 A valmont COMPANY

Engineering Support Team:
 1-888-753-7446

Locations:
 New York, NY
 Atlanta, GA
 Los Angeles, CA
 Plymouth, IN
 Salem, OR
 Dallas, TX

REV	DESCRIPTION OF REVISIONS	CPD	BY	DATE
A	UQB4 revised to meet modern loading	4863	JET	6/3/2019

REVISION HISTORY

PART NO. UQB4	PAGE 1 OF 1
DWG. NO. UQB4	