

PARTS LIST						
ITEM	QTY	PART NO.	PART DESCRIPTION	LENGTH	UNIT WT.	NET WT.
1	1	2PBG	24" PIPE MOUNT STANDOFF ARM		71.96	71.96
2	1	CFM	UPPER GATE FOOT WELDMENT		13.90	13.90
3	1	CFS	LOWER GATE FOOT WELDMENT		12.72	12.72
4	2	A1205	1/2" x 5" A325 HDG BOLT	5 in.	0.34	0.69
5	112	G12LW	1/2" HDG LOCKWASHER		0.01	1.56
6	2	A12NUT	1/2" HDG A325 HEX NUT		0.07	0.14
7	110	G12NUT	1/2" HDG HEAVY 2H HEX NUT		0.07	7.87
8	8	G12R-12	1/2" x 12" THREADED ROD (HDG.)		0.35	2.81
8	8	G12R-15	1/2" x 15" THREADED ROD (HDG.)		0.84	6.69
9	2	GBB	GATE BACKING BAR		4.53	9.06
10	2	SCX4	CROSSOVER PLATE	8.500 in	6.02	12.04
11	4	X-UB1358	1/2" X 3-5/8" X 5-1/2" X 3" U-BOLT (HDG.)		0.66	2.63
12	96	G12FW	1/2" HDG USS FLATWASHER		0.03	3.27
13	2	P2126	2-3/8" OD X 126" SCH 40 GALVANIZED PIPE	126	40.37	80.74
14	4	X-UB1300	1/2" X 3" X 5" X 2" U-BOLT (HDG.)		0.66	2.63
15	2	A	B	C	D	
16	8	SCX1	CROSSOVER PLATE 2-3/8" X 2-3/8"		3.71	29.67
17	2	P2150	2-3/8" OD X 150" SCH 40 GALVANIZED PIPE	150.0000 in	48.06	96.11
18	32	X-UB1212	1/2" X 2-1/2" X 4-1/2" X 2" U-BOLT (HDG.)		0.63	20.00
19	2	X-STA3	STIFF ARM ANGLE BRACKET	2.500 in	1.39	2.78
20	4	X-STU	STIFF ARM CHANNEL BRACKET		1.37	5.49
21	2	SAM	STIFF ARM MOUNT CLAMP		0.77	1.54
22	2	ACP	4-1/16" CLAMP HALF, 1/4" THK.		0.65	1.31
23	4	G1203	1/2" x 3" HDG HEX BOLT GR5 FULL THREAD	3	0.22	0.87
24	2	G12112	1/2" x 1-1/2" HDG HEX BOLT GR5	1 1/2	0.15	0.30
25	2	G58112	5/8" x 1-1/2" HDG BOLT	1.5	0.25	0.49
26	2	G58LW	5/8" HDG LOCKWASHER		0.03	0.05
27	2	G58NUT	5/8" HDG HEAVY 2H HEX NUT		0.13	0.26
28	4	G12R-10	1/2" x 10" THREADED ROD (HDG.)		0.35	1.41

ANTENNA MOUNTING PIPES						
"ASSEMBLY NO."	PART NO. "A"	PART DESCRIPTION "B"	LENGTH "C"	UNIT WT. "D"	TOTAL WT.	
USF10-372-U	P272	2-3/8" O.D. SCH. 40 PIPE	72"	23.07	452.64	
USF10-384-U	P284	2-3/8" O.D. SCH. 40 PIPE	84"	26.91	464.16	
USF10-396-U	P296	2-3/8" O.D. SCH. 40 PIPE	96"	30.76	475.71	

TOLERANCE NOTES
 TOLERANCES ON DIMENSIONS, UNLESS OTHERWISE NOTED ARE:
 SAWED, SHEARED AND GAS CUT EDGES ($\pm 0.030"$)
 DRILLED AND GAS CUT HOLES ($\pm 0.030"$) - NO CONING OF HOLES
 LASER CUT EDGES AND HOLES ($\pm 0.010"$) - NO CONING OF HOLES
 BENDS ARE $\pm 1/2$ DEGREE
 ALL OTHER MACHINING ($\pm 0.030"$)
 ALL OTHER ASSEMBLY ($\pm 0.060"$)

PROPRIETARY NOTE:
 THE DATA AND TECHNIQUES CONTAINED IN THIS DRAWING ARE PROPRIETARY INFORMATION OF VALMONT INDUSTRIES AND CONSIDERED A TRADE SECRET. ANY USE OR DISCLOSURE WITHOUT THE CONSENT OF VALMONT INDUSTRIES IS STRICTLY PROHIBITED.

DESCRIPTION		
ULTIMATE SECTOR FRAME 10'-6" FACE WIDTH		
CPD NO. 5001	DRAWN BY CEK 4/12/2011	ENG. APPROVAL
CLASS 81	SUB 01	DRAWING USAGE CUSTOMER
		CHECKED BY BMC 4/28/2011

 A valmont COMPANY	Locations: New York, NY Atlanta, GA Los Angeles, CA Plymouth, IN Salem, OR Dallas, TX
	Engineering Support Team: 1-888-753-7446
PART NO. SEE "ASSEMBLY NO."	DWG. NO. USF10-3XX-U

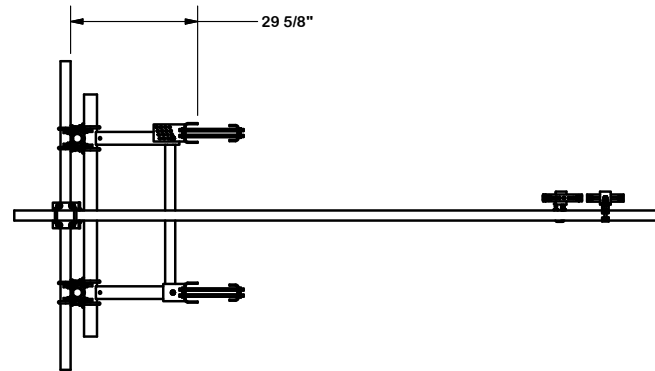
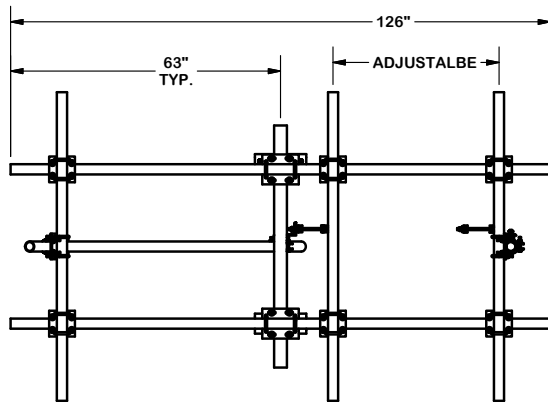
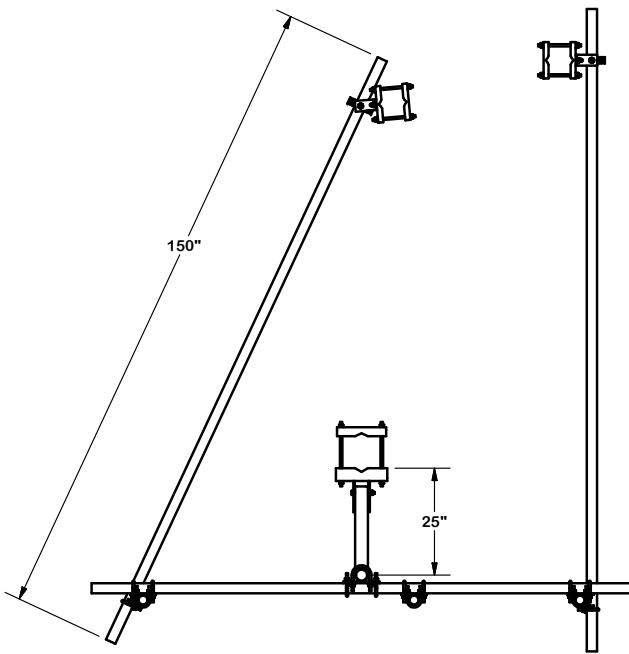

TOLERANCE NOTES

TOLERANCES ON DIMENSIONS, UNLESS OTHERWISE NOTED ARE:
 SAWED, SHEARED AND GAS CUT EDGES ($\pm 0.030"$)
 DRILLED AND GAS CUT HOLES ($\pm 0.030"$) - NO CONING OF HOLES
 LASER CUT EDGES AND HOLES ($\pm 0.010"$) - NO CONING OF HOLES
 BENDS ARE $\pm 1/2$ DEGREE
 ALL OTHER MACHINING ($\pm 0.030"$)
 ALL OTHER ASSEMBLY ($\pm 0.060"$)

PROPRIETARY NOTE:
 THE DATA AND TECHNIQUES CONTAINED IN THIS DRAWING ARE PROPRIETARY INFORMATION OF VALMONT INDUSTRIES AND CONSIDERED A TRADE SECRET. ANY USE OR DISCLOSURE WITHOUT THE CONSENT OF VALMONT INDUSTRIES IS STRICTLY PROHIBITED.

DESCRIPTION
 ULTIMATE SECTOR FRAME
 10'-6" FACE WIDTH

CPD NO. 5001	DRAWN BY CEK 4/12/2011	ENG. APPROVAL
CLASS 81	SUB 01	DRAWING USAGE CUSTOMER
		CHECKED BY BMC 4/28/2011

SITE PRO 1
 A valmont COMPANY

Engineering Support Team:
 1-888-753-7446

Locations:
 New York, NY
 Atlanta, GA
 Los Angeles, CA
 Plymouth, IN
 Salem, OR
 Dallas, TX

PART NO. SEE "ASSEMBLY NO."	PAGE 2 OF 2
DWG. NO. USF10-3XX-U	