

PARTS LIST						
ITEM	QTY	PART NO.	PART DESCRIPTION	LENGTH	UNIT WT.	NET WT.
1	1	2PBG	24" PIPE MOUNT STANDOFF ARM		71.96	71.96
2	1	CFM	UPPER GATE FOOT WELDMENT		13.90	13.90
3	1	CFS	LOWER GATE FOOT WELDMENT		12.72	12.72
4	2	A1205	1/2" x 5" A325 HDG BOLT	5 in.	0.34	0.69
5	112	G12LW	1/2" HDG LOCKWASHER		0.01	1.56
6	2	A12NUT	1/2" HDG A325 HEX NUT		0.07	0.14
7	110	G12NUT	1/2" HDG HEAVY 2H HEX NUT		0.07	7.87
8	8	G12R-12	1/2" x 12" THREADED ROD (HDG.)		0.35	2.81
8	8	G12R-15	1/2" x 15" THREADED ROD (HDG.)		0.84	6.69
9	2	GBB	GATE BACKING BAR		4.53	9.06
10	2	SCX4	CROSSOVER PLATE	8.500 in	6.02	12.04
11	4	X-UB1358	1/2" X 3-5/8" X 5-1/2" X 3" U-BOLT (HDG.)		0.66	2.63
12	96	G12FW	1/2" HDG USS FLATWASHER		0.03	3.27
13	4	P2150	2-3/8" OD X 150" SCH 40 GALVANIZED PIPE	150.0000 in	48.06	192.23
14	4	X-UB1300	1/2" X 3" X 5" X 2" U-BOLT (HDG.)		0.66	2.63
15	2	A	B	C	D	
16	8	SCX1	CROSSOVER PLATE 2-3/8" X 2-3/8"		3.71	29.67
17	32	X-UB1212	1/2" X 2-1/2" X 4-1/2" X 2" U-BOLT (HDG.)		0.63	20.00
18	2	X-STA3	STIFF ARM ANGLE BRACKET	2.500 in	1.39	2.78
19	4	X-STU	STIFF ARM CHANNEL BRACKET		1.37	5.49
20	2	SAM	STIFF ARM MOUNT CLAMP		0.77	1.54
21	2	ACP	4-1/16" CLAMP HALF, 1/4" THK.		0.65	1.31
22	4	G1203	1/2" x 3" HDG HEX BOLT GR5 FULL THREAD	3	0.22	0.87
23	2	G12112	1/2" x 1-1/2" HDG HEX BOLT GR5	1 1/2	0.15	0.30
24	2	G58112	5/8" x 1-1/2" HDG BOLT	1.5	0.25	0.49
25	2	G58LW	5/8" HDG LOCKWASHER		0.03	0.05
26	2	G58NUT	5/8" HDG HEAVY 2H HEX NUT		0.13	0.26
27	4	G12R-10	1/2" x 10" THREADED ROD (HDG.)		0.35	1.41

ANTENNA MOUNTING PIPES						
"ASSEMBLY NO."	PART NO. "A"	PART DESCRIPTION "B"	LENGTH "C"	UNIT WT. "D"	TOTAL WT.	
USF12-372-U	P272	2-3/8" O.D. SCH. 40 PIPE	72"	23.07	468.02	
USF12-384-U	P284	2-3/8" O.D. SCH. 40 PIPE	84"	26.91	479.54	
USF12-396-U	P296	2-3/8" O.D. SCH. 40 PIPE	96"	30.76	491.09	

**TOLERANCE NOTES**  
 TOLERANCES ON DIMENSIONS, UNLESS OTHERWISE NOTED ARE:  
 SAWED, SHEARED AND GAS CUT EDGES ( $\pm 0.030"$ )  
 DRILLED AND GAS CUT HOLES ( $\pm 0.030"$ ) - NO CONING OF HOLES  
 LASER CUT EDGES AND HOLES ( $\pm 0.010"$ ) - NO CONING OF HOLES  
 BENDS ARE  $\pm 1/2$  DEGREE  
 ALL OTHER MACHINING ( $\pm 0.030"$ )  
 ALL OTHER ASSEMBLY ( $\pm 0.060"$ )

**PROPRIETARY NOTE:**  
 THE DATA AND TECHNIQUES CONTAINED IN THIS DRAWING ARE PROPRIETARY INFORMATION OF VALMONT INDUSTRIES AND CONSIDERED A TRADE SECRET. ANY USE OR DISCLOSURE WITHOUT THE CONSENT OF VALMONT INDUSTRIES IS STRICTLY PROHIBITED.

DESCRIPTION		
ULTIMATE SECTOR FRAME 12'-6" FACE WIDTH		
CPD NO. 5001	DRAWN BY CEK 4/12/2011	ENG. APPROVAL
CLASS 81	SUB 01	DRAWING USAGE CUSTOMER
		CHECKED BY BMC 4/28/2011

 A valmont COMPANY	Locations: New York, NY Atlanta, GA Los Angeles, CA Plymouth, IN Salem, OR Dallas, TX
	Engineering Support Team: 1-888-753-7446
PART NO.	"SEE ASSEMBLY NO."
DWG. NO.	USF12-3XX-U

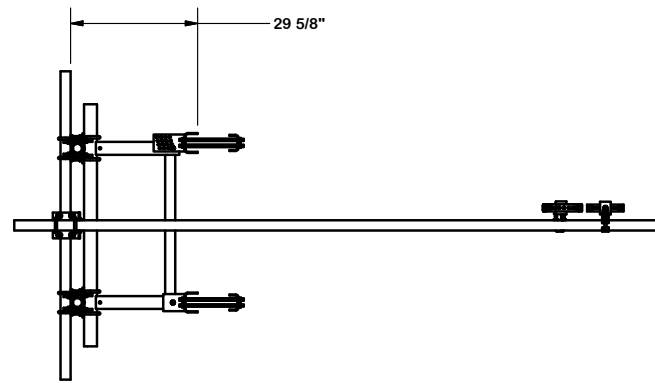
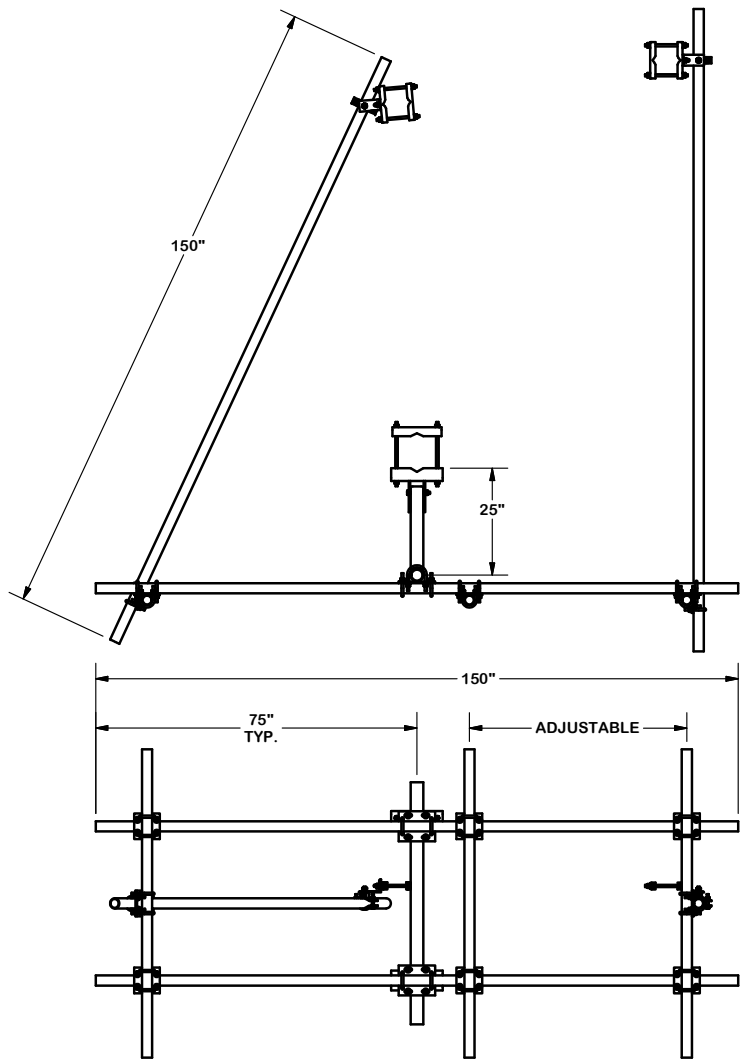

**TOLERANCE NOTES**

TOLERANCES ON DIMENSIONS, UNLESS OTHERWISE NOTED ARE:  
 SAWED, SHEARED AND GAS CUT EDGES ( $\pm 0.030"$ )  
 DRILLED AND GAS CUT HOLES ( $\pm 0.030"$ ) - NO CONING OF HOLES  
 LASER CUT EDGES AND HOLES ( $\pm 0.010"$ ) - NO CONING OF HOLES  
 BENDS ARE  $\pm 1/2$  DEGREE  
 ALL OTHER MACHINING ( $\pm 0.030"$ )  
 ALL OTHER ASSEMBLY ( $\pm 0.060"$ )

PROPRIETARY NOTE:  
 THE DATA AND TECHNIQUES CONTAINED IN THIS DRAWING ARE PROPRIETARY INFORMATION OF VALMONT INDUSTRIES AND CONSIDERED A TRADE SECRET. ANY USE OR DISCLOSURE WITHOUT THE CONSENT OF VALMONT INDUSTRIES IS STRICTLY PROHIBITED.

DESCRIPTION  
 ULTIMATE SECTOR FRAME  
 12'-6" FACE WIDTH

CPD NO. 5001	DRAWN BY CEK 4/12/2011	ENG. APPROVAL
CLASS 81	SUB 01	DRAWING USAGE CUSTOMER
		CHECKED BY BMC 4/28/2011

**SITE PRO 1**  
 A valmont COMPANY

Engineering  
 Support Team:  
 1-888-753-7446

Locations:  
 New York, NY  
 Atlanta, GA  
 Los Angeles, CA  
 Plymouth, IN  
 Salem, OR  
 Dallas, TX

PART NO. "SEE ASSEMBLY NO."	PAGE 2 OF 2
DWG. NO. USF12-3XX-U	