

PARTS LIST						
ITEM	QTY	PART NO.	PART DESCRIPTION	LENGTH	UNIT WT.	NET WT.
1	1	X-UT4	4-RUN T-BRACKET WELDMNT		1.89	1.89

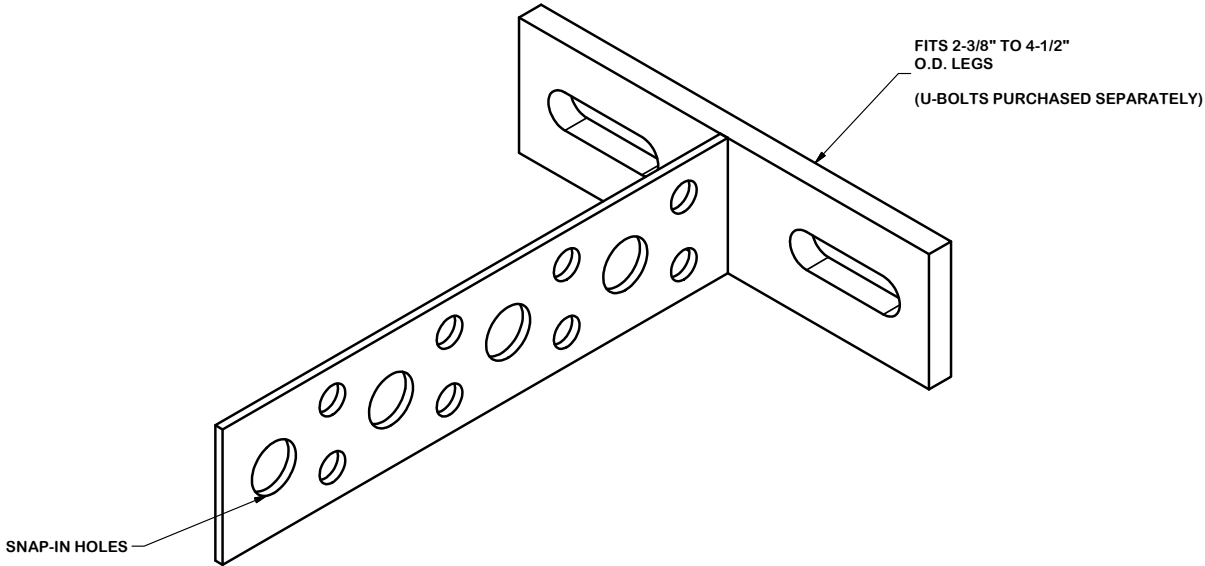

**TOLERANCE NOTES**

**TOLERANCES ON DIMENSIONS, UNLESS OTHERWISE NOTED ARE:  
 SAWED, SHEARED AND GAS CUT EDGES ( $\pm 0.030$ " )  
 DRILLED AND GAS CUT HOLES ( $\pm 0.030$ " ) - NO CONING OF HOLES  
 LASER CUT EDGES AND HOLES ( $\pm 0.010$ " ) - NO CONING OF HOLES  
 BENDS AND ANGLES ARE  $\pm 1/2$  DEGREE  
 ALL OTHER MACHINING ( $\pm 0.030$ " )  
 ALL OTHER ASSEMBLY ( $\pm 0.060$ " )**

**PROPRIETARY NOTE:  
 THE DATA AND TECHNIQUES CONTAINED IN THIS DRAWING ARE PROPRIETARY INFORMATION OF VALMONT  
 INDUSTRIES AND CONSIDERED A TRADE SECRET. ANY USE OR DISCLOSURE WITHOUT THE CONSENT OF  
 VALMONT INDUSTRIES IS STRICTLY PROHIBITED.**

DESCRIPTION  
**PIM BUSTER T-BRACKET  
 4 SNAP-IN HOLES**

CPD NO.	DRAWN BY <b>CEK 8/12/2019</b>	ENG. APPROVAL
CLASS <b>81</b>	SUB <b>01</b>	DRAWING USAGE <b>CUSTOMER</b>
	CHECKED BY <b>BMC 8/26/2019</b>	

**SITE PRO 1**  
 A valmont COMPANY

Locations:  
 New York, NY  
 Atlanta, GA  
 Los Angeles, CA  
 Plymouth, IN  
 Salem, OR  
 Dallas, TX  
 Tampa, FL

Engineering Support Team:  
 1-888-753-7446

PART NO.	<b>UT4-FB</b>
DWG. NO.	<b>UT4-FB</b>