

PARTS LIST						
ITEM	QTY	PART NO.	PART DESCRIPTION	LENGTH	UNIT WT.	NET WT.
1	1	X-UT8	8-RUN T-BRACKET WELDMENT		2.69	2.69

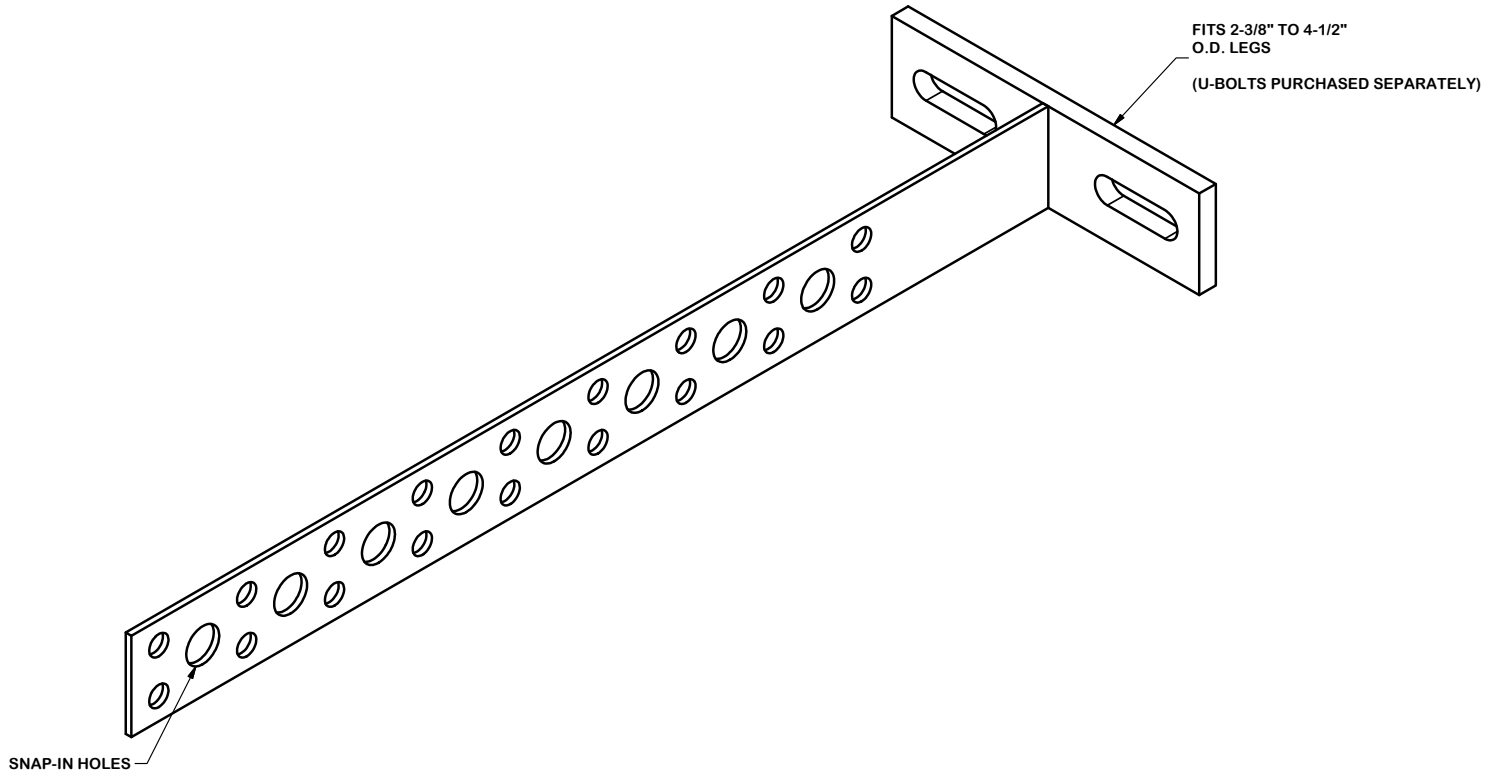

TOLERANCE NOTES

TOLERANCES ON DIMENSIONS, UNLESS OTHERWISE NOTED ARE:
SAWED, SHEARED AND GAS CUT EDGES (± 0.030 ")
DRILLED AND GAS CUT HOLES (± 0.030 ") - NO CONING OF HOLES
LASER CUT EDGES AND HOLES (± 0.010 ") - NO CONING OF HOLES
BENDS AND ANGLES ARE $\pm 1/2$ DEGREE
ALL OTHER MACHINING (± 0.030 ")
ALL OTHER ASSEMBLY (± 0.060 ")

PROPRIETARY NOTE:
 THE DATA AND TECHNIQUES CONTAINED IN THIS DRAWING ARE PROPRIETARY INFORMATION OF VALMONT INDUSTRIES AND CONSIDERED A TRADE SECRET. ANY USE OR DISCLOSURE WITHOUT THE CONSENT OF VALMONT INDUSTRIES IS STRICTLY PROHIBITED.

DESCRIPTION
**PIM BUSTER T-BRACKET
 8 SNAP-IN HOLES**

CPD NO.	DRAWN BY	ENG. APPROVAL
CLASS	SUB	DRAWING USAGE
81	01	CUSTOMER
	CHECKED BY	
	BMC	8/26/2019

SITE PRO 1

Locations:
 New York, NY
 Atlanta, GA
 Los Angeles, CA
 Plymouth, IN
 Salem, OR
 Dallas, TX
 Tampa, FL

Engineering Support Team:
 1-888-753-7446

A valmont COMPANY

PART NO.	UT8-FB	PAGE
DWG. NO.	UT8-FB	1 OF 1