

SECTION LEG
1-1/4" MIN. - 4-1/2" O.D. MAX.
(REFERENCE ONLY)

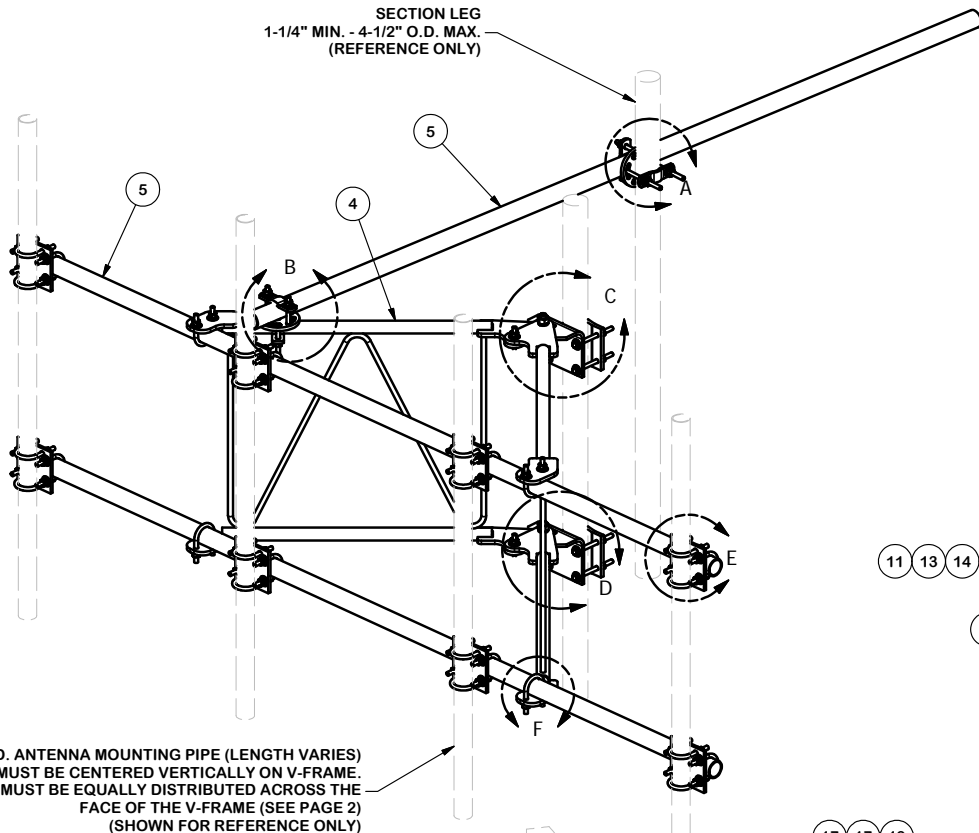

2-3/8" O.D. ANTENNA MOUNTING PIPE (LENGTH VARIES)
MUST BE CENTERED VERTICALLY ON V-FRAME.
PIPES MUST BE EQUALLY DISTRIBUTED ACROSS THE
FACE OF THE V-FRAME (SEE PAGE 2)
(SHOWN FOR REFERENCE ONLY)

PARTS LIST						
ITEM	QTY	PART NO.	PART DESCRIPTION	LENGTH	UNIT WT.	NET WT.
1	1	X-192043	UPPER MOUNTING BRACKET FOR V-FRAME		8.73	8.73
2	1	X-192044	LOWER MOUNTING BRACKET FOR V-FRAME		8.73	8.73
3	2	X-195999	BACKING PLATE	6 9/16	5.73	11.46
4	2	X-197544	SUPPORT ARM, BC-FRAME		43.48	86.96
5	3	P2126	2-3/8" OD X 126" SCH 40 GALVANIZED PIPE	126"	40.75	122.26
6	2	X-127594	FLAT DISK CLAMP PLATE 4" CENTERS (GALV.)		2.48	4.97
7	4	X-100064	CLAMP (S) (4" V-CLAMP) GALVANIZED		0.91	3.65
8	8	SCX1	CROSSOVER PLATE 2-3/8" X 2-3/8"	6	3.71	29.67
9	10	G12065	1/2" x 6-1/2" HDG HEX BOLT GR5 FULL THREAD		0.41	4.09
10	6	G1204	1/2" x 4" HDG HEX BOLT GR5 FULL THREAD		0.27	1.62
11	2	G12212	1/2" x 2-1/2" HDG HEX BOLT GR5		0.20	0.41
12	36	X-UB1212	1/2" X 2-1/2" X 4-1/2" X 2" GALV. U-BOLT		0.66	23.63
13	92	G12FW	1/2" HDG USS FLATWASHER	0.095	0.03	3.14
14	90	G12LW	1/2" HDG LOCKWASHER	.125	0.01	1.25
15	90	G12NUT	1/2" HDG HEAVY 2H HEX NUT		0.07	6.45
16	2	A34234	3/4"-10 X 2-3/4" A325 BOLT WITH 1-3/8" THREAD		0.54	1.07
17	2	G34LW	3/4" HDG LOCKWASHER		0.04	0.09
18	2	G34NUT	3/4" HDG HEAVY 2H HEX NUT		0.21	0.42
					TOTAL WT. #	284.85

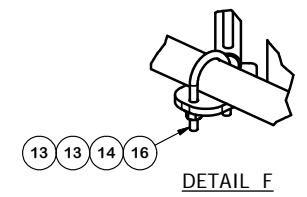
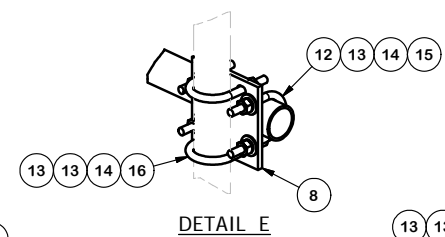
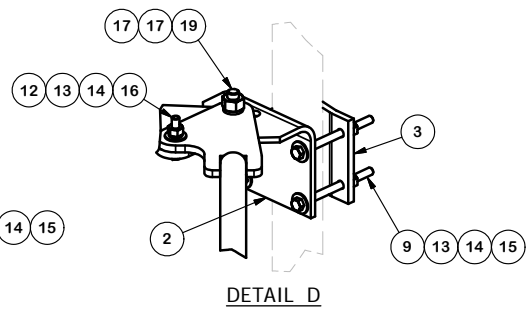
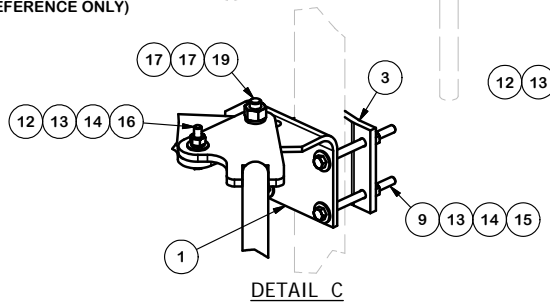
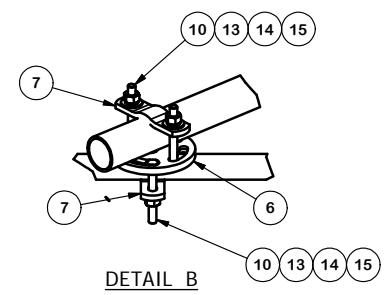
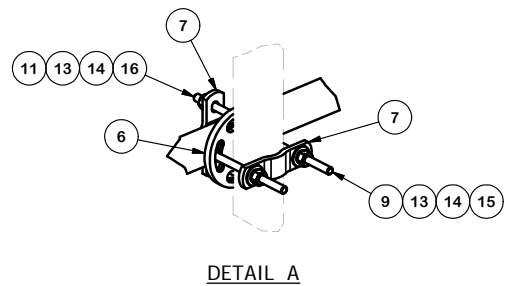

TOLERANCE NOTES
TOLERANCES ON DIMENSIONS, UNLESS OTHERWISE NOTED ARE:
SAWED, SHEARED AND GAS CUT EDGES ($\pm 0.030"$)
DRILLED AND GAS CUT HOLES ($\pm 0.030"$) - NO CONING OF HOLES
LASER CUT EDGES AND HOLES ($\pm 0.010"$) - NO CONING OF HOLES
BENDS ARE $\pm 1/2$ DEGREE
ALL OTHER MACHINING ($\pm 0.030"$)
ALL OTHER ASSEMBLY ($\pm 0.060"$)

PROPRIETARY NOTE:
THE DATA AND TECHNIQUES CONTAINED IN THIS DRAWING ARE PROPRIETARY INFORMATION OF VALMONT INDUSTRIES AND CONSIDERED A TRADE SECRET. ANY USE OR DISCLOSURE WITHOUT THE CONSENT OF VALMONT INDUSTRIES IS STRICTLY PROHIBITED.

DESCRIPTION		10'-6" V-FRAME ASSEMBLY W/ STIFF ARM	
CPD NO. 4752	DRAWN BY RH18 10/1/2010	ENG. APPROVAL	
CLASS 81	SUB 01	DRAWING USAGE CUSTOMER	CHECKED BY BMC 11/13/2015

<p>A valmont COMPANY</p>	Locations: New York, NY Atlanta, GA Los Angeles, CA Plymouth, IN Salem, OR Dallas, TX
	Engineering Support Team: 1-888-753-7446
PART NO.	VFA10-U
DWG. NO.	VFA10-U

REV	DESCRIPTION OF REVISIONS	CPD	CEK	DATE
1	P1126 CHANGED TO P2126	4752	CEK	11/13/2015

REVISION HISTORY

A MINIMUM OF ONE TIE-BACK MUST BE USED FOR THIS ASSEMBLY.

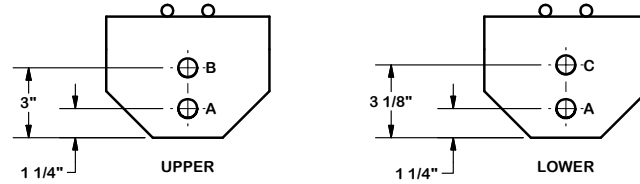
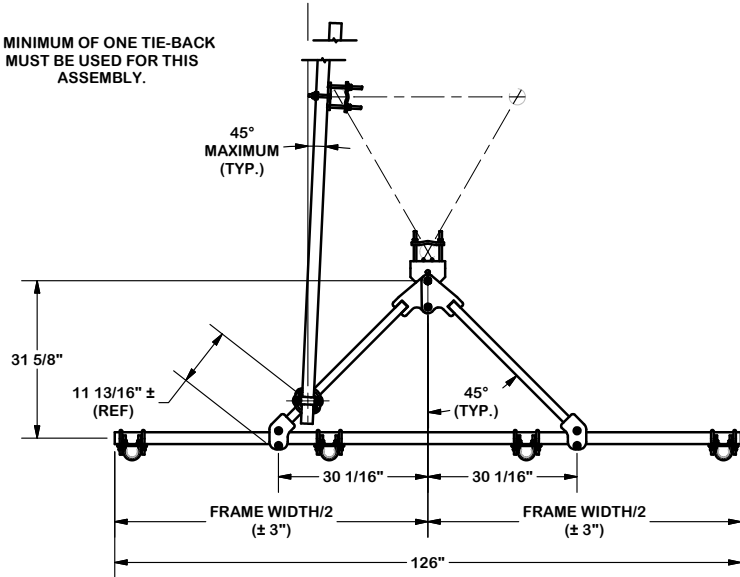

NOTES:

1. USE HOLE "A" IN UPPER AND LOWER BRACKETS FOR STRAIGHT LEGS.
2. USE HOLE "A" IN UPPER BRACKET AND HOLE "C" IN LOWER BRACKET FOR 2' IN 20' TAPER LEGS. (3.309°)
3. USE HOLE "B" IN UPPER BRACKET AND HOLE "C" IN LOWER BRACKET FOR 6" IN 20' TAPER LEGS. (0.827°)

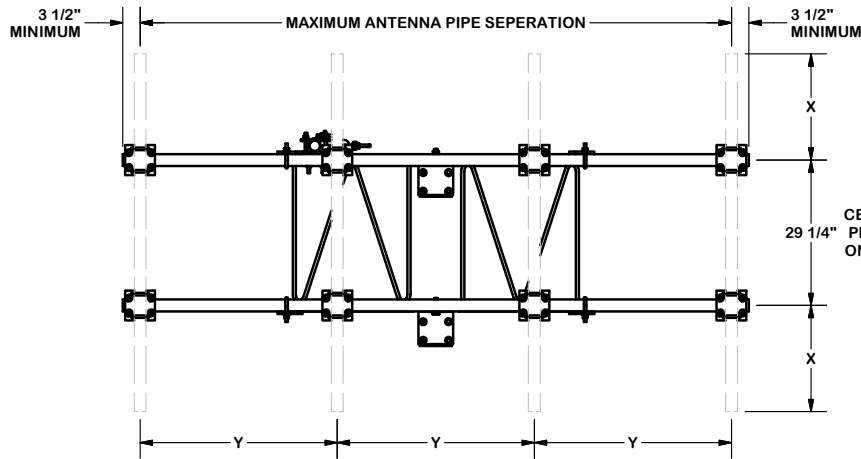

PIPES MUST BE SPACED EVENLY ACROSS THE FACE OF THE V-FRAME (± 3")

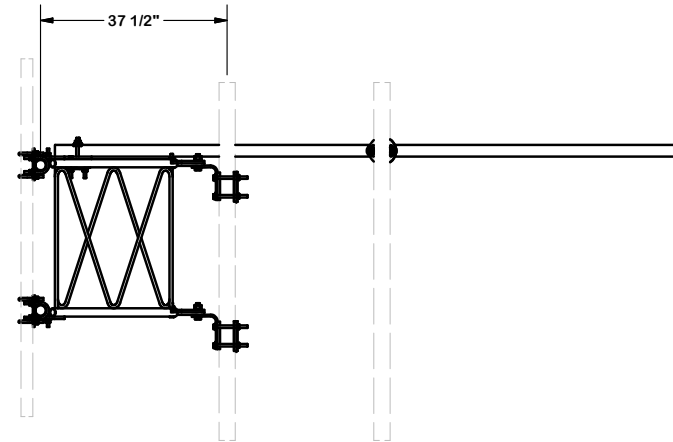

TOLERANCE NOTES

TOLERANCES ON DIMENSIONS, UNLESS OTHERWISE NOTED ARE:
 SAWED, SHEARED AND GAS CUT EDGES (± 0.030")
 DRILLED AND GAS CUT HOLES (± 0.030") - NO CONING OF HOLES
 LASER CUT EDGES AND HOLES (± 0.010") - NO CONING OF HOLES
 BENDS ARE ± 1/2 DEGREE
 ALL OTHER MACHINING (± 0.030")
 ALL OTHER ASSEMBLY (± 0.060")

PROPRIETARY NOTE:
 THE DATA AND TECHNIQUES CONTAINED IN THIS DRAWING ARE PROPRIETARY INFORMATION OF VALMONT INDUSTRIES AND CONSIDERED A TRADE SECRET. ANY USE OR DISCLOSURE WITHOUT THE CONSENT OF VALMONT INDUSTRIES IS STRICTLY PROHIBITED.

DESCRIPTION
 10'-6"
 V-FRAME ASSEMBLY
 W/ STIFF ARM

CPD NO. 4752	DRAWN BY RH18 10/1/2010	ENG. APPROVAL
CLASS 81	SUB 01	DRAWING USAGE CUSTOMER
	CHECKED BY BMC 11/13/2015	



Locations:
 New York, NY
 Atlanta, GA
 Los Angeles, CA
 Plymouth, IN
 Salem, OR
 Dallas, TX

Engineering
 Support Team:
 1-888-753-7446

PART NO. VFA10-U	PAGE 2 OF 2
DWG. NO. VFA10-U	

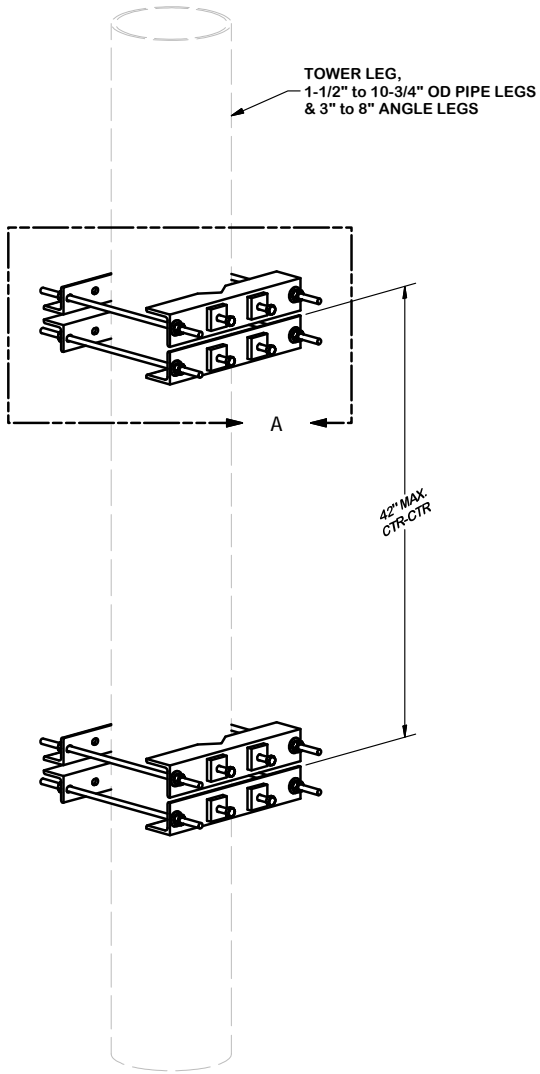

PARTS LIST						
ITEM	QTY	PART NO.	PART DESCRIPTION	LENGTH	UNIT WT.	NET WT.
1	4	X-158320	ANGLE CLAMP	16 1/2 in	8.51	34.03
2	4	X-126501	BRACKET ANGLE LEG MOUNTING	16 1/2 in	7.13	28.51
3	8	G12R-20	1/2" x 20" GALV. THREADED ROD		1.12	8.92
4	8	G1203	1/2" x 3" HDG HEX BOLT GR5 FULL THREAD	3 in	0.22	1.74
5	24	G12FW	1/2" HDG USS FLATWASHER		0.03	0.82
6	24	G12LW	1/2" HDG LOCKWASHER		0.01	0.33
7	24	G12NUT	1/2" HDG HEAVY 2H HEX NUT		0.07	1.72
8	8	X-124312	1/2" X 2" X 2" ANGLE SPACER; WITH 9/16" HOLE		0.53	4.26
					TOTAL WT. #	77.61

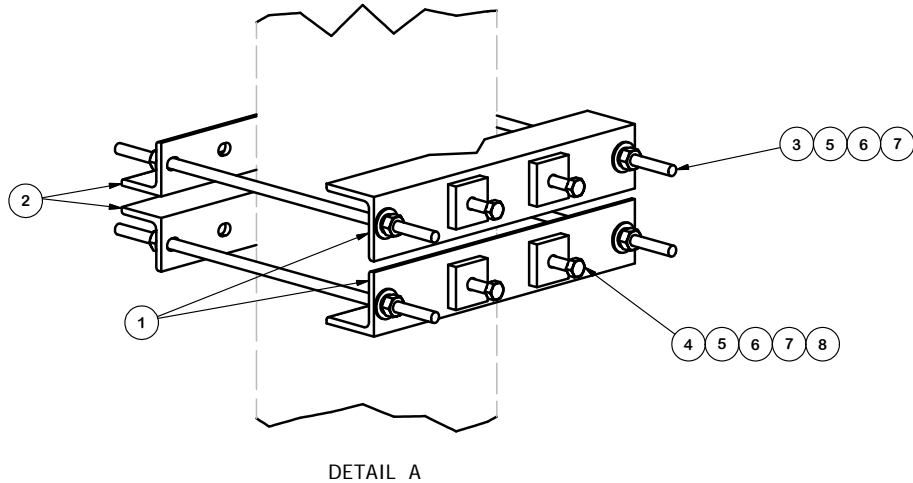

TOLERANCE NOTES

TOLERANCES ON DIMENSIONS, UNLESS OTHERWISE NOTED ARE:
 SAWED, SHEARED AND GAS CUT EDGES ($\pm 0.030"$)
 DRILLED AND GAS CUT HOLES ($\pm 0.030"$) - NO CONING OF HOLES
 LASER CUT EDGES AND HOLES ($\pm 0.010"$) - NO CONING OF HOLES
 BENDS ARE $\pm 1/2$ DEGREE
 ALL OTHER MACHINING ($\pm 0.030"$)
 ALL OTHER ASSEMBLY ($\pm 0.060"$)

PROPRIETARY NOTE:
 THE DATA AND TECHNIQUES CONTAINED IN THIS DRAWING ARE PROPRIETARY INFORMATION OF VALMONT INDUSTRIES AND CONSIDERED A TRADE SECRET. ANY USE OR DISCLOSURE WITHOUT THE CONSENT OF VALMONT INDUSTRIES IS STRICTLY PROHIBITED.

DESCRIPTION
 LARGE LEG
 ADAPTER KIT
 SITE PRO 1

CPD NO. 4718	DRAWN BY RH18 3/30/2010	ENG. APPROVAL
CLASS 81	SUB 01	DRAWING USAGE CUSTOMER
		CHECKED BY BMC 9/16/2010

SITE PRO 1
 Engineering Support Team:
 1-888-753-7446

Locations:
 New York, NY
 Atlanta, GA
 Los Angeles, CA
 Plymouth, IN
 Salem, OR
 Dallas, TX

A valmont COMPANY

PART NO. LLEG-K	PAGE 1 OF 1
DWG. NO. LLEG-K	