

DETAIL A

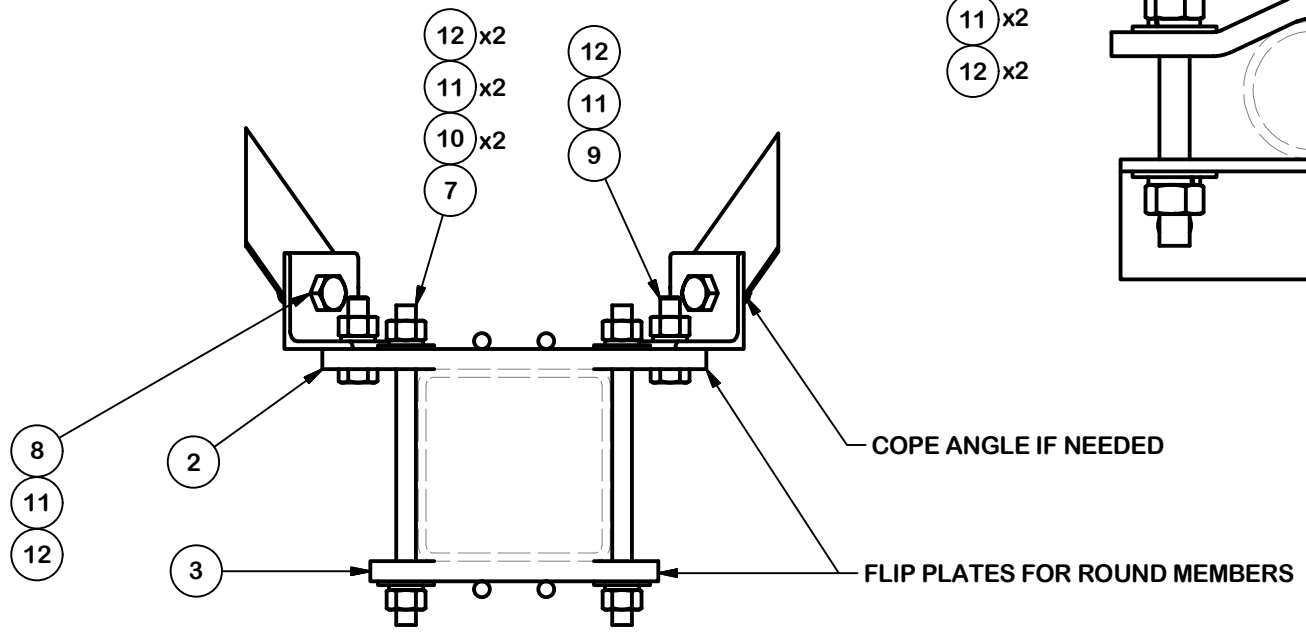

SECTION B-B

FIELD CUT AND DRILL TO FIT AND THEN COLD GALVANIZE.

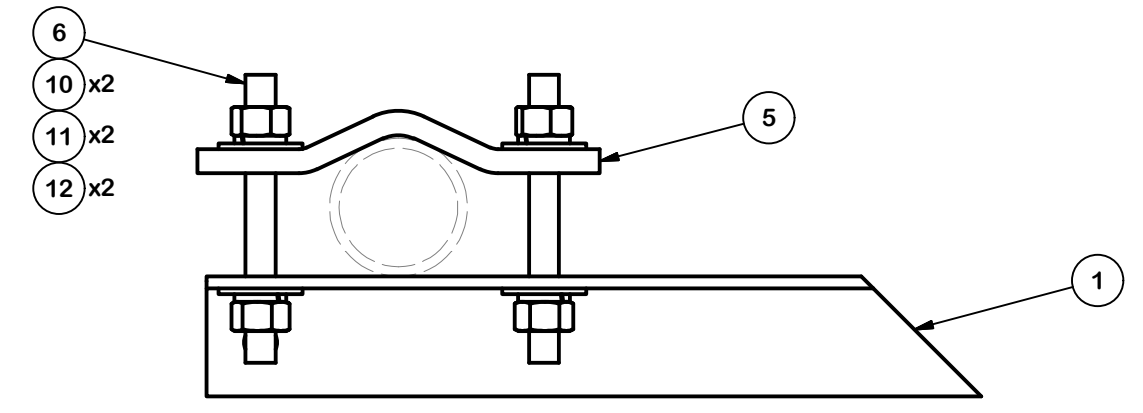

SECTION C-C

PARTS LIST						
ITEM	QTY	PART NO.	PART DESCRIPTION	LENGTH	UNIT WT.	NET WT.
1	2	L252525-8	ANGLE BRACE (FIELD MODIFICATION REQUIRED)	96 in	34.52	69.04
2	1	PL625-72512	SUPPORT RAIL BRACING MAIN PLATE WELDMENT		16.36	16.36
3	1	PL625-7259	SUPPORT RAIL BRACING PLATE WELDMENT		12.41	12.41
4	2	AL-333	CLIP ANGLE	3 in	1.25	2.50
5	2	VCP	1/2" x 2" FLAT STOCK (A36)	8 21/32 in	2.44	4.89
6	4	G58R-10	5/8" x 10" THREADED ROD (HDG.)		0.87	3.48
7	4	G58R-18	5/8" x 18" THREADED ROD (HDG.)		1.57	6.27
8	2	A58134	5/8" X 1-3/4" HDG A325 BOLT	1 3/4 in	0.27	0.54
9	2	A582114	5/8" x 2-1/4" HDG A325 HEX BOLT	2 1/4 in	0.31	0.62
10	16	G58FW	5/8" HDG USS FLATWASHER		0.07	1.13
11	20	G58LW	5/8" HDG LOCKWASHER		0.03	0.52
12	20	G58NUT	5/8" HDG HEAVY 2H HEX NUT		0.13	2.60
TOTAL WT. #						165.57

Valmont Site Pro 1
 Lori.Espinosa@valmont.com
 (631) 715-3045
 www.sitepro1.com

TOLERANCE NOTES
 TOLERANCES ON DIMENSIONS, UNLESS OTHERWISE NOTED ARE:
 SAWED, SHEARED AND GAS CUT EDGES (± 0.030")
 DRILLED AND GAS CUT HOLES (± 0.030") - NO CONING OF HOLES
 LASER CUT EDGES AND HOLES (± 0.010") - NO CONING OF HOLES
 BENDS ARE ± 1/2 DEGREE
 ALL OTHER MACHINING (± 0.030")
 ALL OTHER ASSEMBLY (± 0.060")

PROPRIETARY NOTE:
 THE DATA AND TECHNIQUES CONTAINED IN THIS DRAWING ARE PROPRIETARY INFORMATION OF VALMONT INDUSTRIES AND CONSIDERED A TRADE SECRET. ANY USE OR DISCLOSURE WITHOUT THE CONSENT OF VALMONT INDUSTRIES IS STRICTLY PROHIBITED.

DESCRIPTION			
SUPPORT RAIL BRACING KIT			
CPD NO.	DRAWN BY	ENG. APPROVAL	
	JFS 3/25/2020	5/10/2020	
CLASS	SUB	DRAWING USAGE	CHECKED BY
87	02	CUSTOMER	BMC 5/10/2020

<p>A valmont COMPANY</p>	<p>Locations: New York, NY Atlanta, GA Los Angeles, CA Plymouth, IN Salem, OR Dallas, TX</p>
	<p>Engineering Support Team: 1-888-753-7446</p>
PART NO.	VZWSMART-PLK8
DWG. NO.	VZWSMART-PLK8