

PARTS LIST						
ITEM	QTY	PART NO.	PART DESCRIPTION	LENGTH	UNIT WT.	NET WT.
1	2	WPBAR	HANGING BAR FOR WORK PLATFORMS		18.08	36.15
2	4	TPWP	TOP/BOTTOM PLATE FOR WORK PLATFORM	8"	3.24	12.96
3	1	GRS12-3	12" WIDE GRIP STRUT	40-1/2"	24.40	24.40
4	8	G12R-8	1/2" x 8" THREADED ROD (HDG.)	8"	0.35	2.81
5	8	G3803	3/8" x 3" HDG HEX BOLT GR5	3"	0.12	0.97
6	17	A12NUT	1/2" HDG A325 HEX NUT		0.07	1.22
7	17	G12LW	1/2" HDG LOCKWASHER		0.01	0.24
8	17	G12FW	1/2" HDG USS FLATWASHER		0.03	0.58
9	8	G38NUT	3/8" HDG HEAVY 2H HEX NUT		0.03	0.27
10	8	G38LW	3/8" HDG LOCKWASHER		0.01	0.05
11	8	G38FW	3/8" HDG USS FLATWASHER		0.01	0.09
12	16	SQW38	3/8" SQUARE WASHER (GALV.)	2"	0.27	4.37
					<b>TOTAL WT. #</b>	<b>84.75</b>

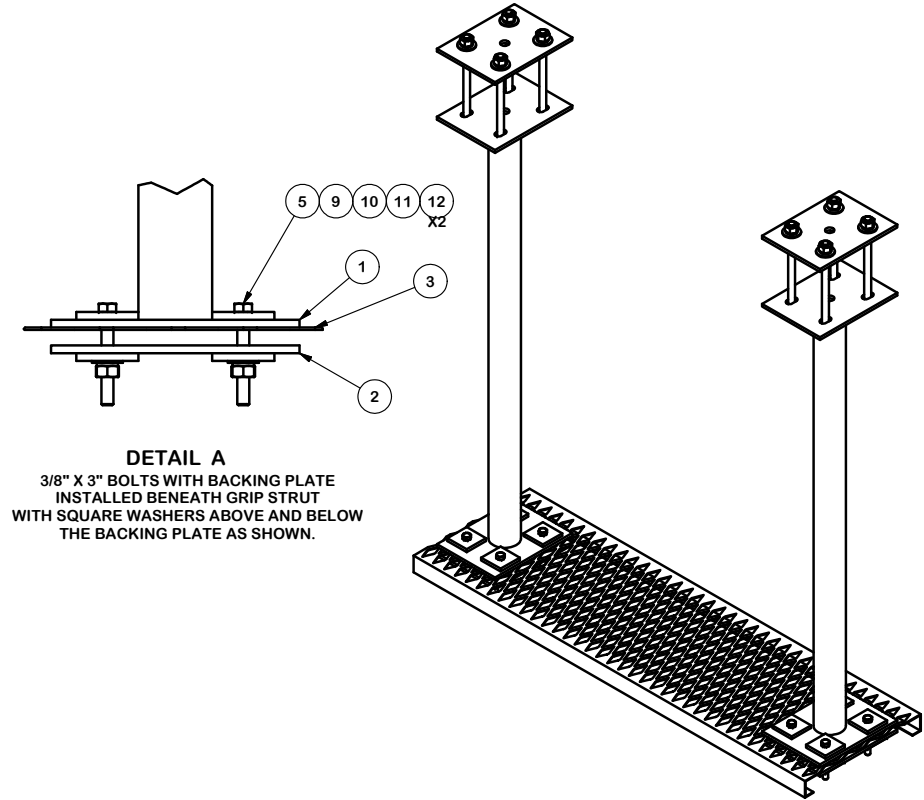

FINISH:  
HOT DIP GALVANIZED.

**TOLERANCE NOTES**  
**TOLERANCES ON DIMENSIONS, UNLESS OTHERWISE NOTED ARE:**  
 SAWED, SHEARED AND GAS CUT EDGES ( $\pm 0.030"$ )  
 DRILLED AND GAS CUT HOLES ( $\pm 0.030"$ ) - NO CONING OF HOLES  
 LASER CUT EDGES AND HOLES ( $\pm 0.010"$ ) - NO CONING OF HOLES  
 BENDS ARE  $\pm 1/2$  DEGREE  
 ALL OTHER MACHINING ( $\pm 0.030"$ )  
 ALL OTHER ASSEMBLY ( $\pm 0.060"$ )

**PROPRIETARY NOTE:**  
 THE DATA AND TECHNIQUES CONTAINED IN THIS DRAWING ARE PROPRIETARY INFORMATION OF VALMONT INDUSTRIES AND CONSIDERED A TRADE SECRET. ANY USE OR DISCLOSURE WITHOUT THE CONSENT OF VALMONT INDUSTRIES IS STRICTLY PROHIBITED.

DESCRIPTION	
3' WORK SUPPORT PLATFORM	
CPD NO.	DRAWN BY
	KC8 8/8/2012
CLASS	DRAWING USAGE
81	CUSTOMER
SUB	CHECKED BY
01	BMC 2/1/2013

 <b>A valmont COMPANY</b>	Engineering Support Team: 1-888-753-7446	Locations: New York, NY Atlanta, GA Los Angeles, CA Plymouth, IN Salem, OR Dallas, TX
	PART NO. <b>WP197</b>	DWG. NO. <b>WP197</b>